

THE THEORY AND USE
OF THE
COMPLEX VARIABLE

www.dbraulibrary.org.in

Downloaded from www.dbraulibrary.org.in

THE THEORY AND USE
OF THE
COMPLEX VARIABLE
AN INTRODUCTION

BY

S. L. GREEN

M.Sc. (LONDON)

SENIOR LECTURER IN APPLIED MATHEMATICS AT QUEEN MARY COLLEGE
(UNIVERSITY OF LONDON)

www.dbraulibrary.org.in

SECOND EDITION



LONDON

SIR ISAAC PITMAN & SONS, LTD.

52049
11 AUG 58

First edition 1939
Reprinted 1944
Second edition 1948
Reprinted 1950
Revised and Reprinted 1953
Reprinted 1957

SIR ISAAC PITMAN & SONS, LTD.
PITMAN HOUSE, PARKER STREET, KINGSWAY, LONDON, W.C.2
THE PITMAN PRESS, BATH
PITMAN HOUSE, BOUVERIE STREET, CARLTON, MELBOURNE
27 BECKETTS BUILDINGS, PRESIDENT STREET, JOHANNESBURG

ASSOCIATED COMPANIES

PITMAN MEDICAL PUBLISHING COMPANY, LTD.
45 NEW OXFORD STREET, LONDON, W.C.1
WWW.PITMAN.CO.UK
PITMAN PUBLISHING CORPORATION
2 WEST 45TH STREET, NEW YORK

SIR ISAAC PITMAN & SONS (CANADA), LTD.
(INCORPORATING THE COMMERCIAL TEXT BOOK COMPANY)
PITMAN HOUSE, 381-383 CHURCH STREET, TORONTO

MADE IN GREAT BRITAIN AT THE PITMAN PRESS, BATH
E7-(T.122)

AUTHOR'S NOTE

SOME corrections and improvements have been made at the suggestion of correspondents, whom I sincerely thank. In particular, I am very grateful to Professor A. Oppenheim, of the University of Malaya, for pointing out a method of constructing a function which has a given real or imaginary part (pp. 51-53).

S. L. G.

QUEEN MARY COLLEGE
(University of London)
March, 1953

PREFACE TO THE FIRST EDITION

THIS book is intended to give an introductory account of the fascinating subject of the complex variable and conformal transformation, with some indication of applications to problems of mathematical physics, aeronautics, and electrical engineering. It demands from the reader little more in the way of preliminary equipment than some knowledge of the calculus (including partial differentiation) and analytical plane geometry.

The needs of those reading Pure Mathematics for the General and Special Honours degrees in Arts and Science of the University of London are practically covered by Chapters I-III, while those presenting Advanced Subjects should be helped by Chapters I-VII. Candidates in Mathematics at the B.Sc. (Eng.) will need Chapters I-III and at least part of Chapters IV and V.

The electrical engineer may read Chapter VIII, on the use of the complex variable in alternating current problems, immediately after Chapters I and II.

Thanks are due to the University of London for permitting the inclusion among the exercises of questions set at examinations for Pass, General and Special Honours degrees in Arts, Science and Engineering.

To Prof. W. J. John, B.Sc., M.I.E.E., Head of the Electrical Engineering Department at Queen Mary College, I am indebted for valuable help in connection with Chapter VIII. To my friend and colleague Mr. R. W. Piper, M.Sc., who has read the manuscript and proofs and made many helpful suggestions and criticisms, I offer hearty thanks.

S. L. G.

QUEEN MARY COLLEGE
(University of London)

www.dbraulibrary.org.in

Downloaded from www.dbraulibrary.org.in

CONTENTS

	PAGE
PREFACE	v
CHAPTER I	
COMPLEX NUMBERS AND THEIR REPRESENTATION	1
Graphical representation of real numbers—Purely imaginary numbers—Complex numbers—The Argand diagram—Vectorial representation of a complex number—Addition and subtraction—Multiplication and division—Geometrical constructions for the product and quotient of two numbers—Exercises	
CHAPTER II	
DE MOIVRE'S THEOREM	20
Theory of equations—De Moivre's theorem—Deductions—The n th roots of a number—Exercises	
CHAPTER III	
INFINITE SERIES—THE EXPONENTIAL, LOGARITHMIC, CIRCULAR, AND HYPERBOLIC FUNCTIONS	30
Absolute convergence of series of complex terms—The Exponential series—Exponential values of circular functions—Application to the summation of series—Logarithms of a complex number—Generalized circular and hyperbolic functions—Exercises	
CHAPTER IV	
FUNCTIONS OF A COMPLEX VARIABLE—CONJUGATE FUNCTIONS—CAUCHY'S THEOREM—CONTOUR INTEGRALS	47
The complex variable—Functions of a complex variable—Conjugate functions—Laplace's equation in polar coordinates—Level curves—The surface of moduli—Condition that a given function should be a modulus—Condition that a family of curves should be level curves—Holomorphic functions—Singularities—Curvilinear integrals—Stokes's theorem—Cauchy's theorem—Rational functions—Taylor and Laurent series for rational functions—Behaviour of a rational function at infinity—Analogous results for functions in general—Exercises	
CHAPTER V	
CONFORMAL TRANSFORMATION	79
Conformal transformation—Inversion with respect to a circle—The reciprocal transformation: the point at infinity—The bilinear transformation—The transformation $w = z + (k^2/z)$ —Transformation of a circle into a circular arc—The transformation $w = \log z$ —The transformation $w = \cosh z$ —The transformation $z = c \tan \frac{1}{2}w$ —Successive transformations—Conformal mapping of a spherical surface on a plane—Exercises	

CHAPTER VI

THE SCHWARZ-CHRISTOFFEL TRANSFORMATION

PAGE

108

Conformal transformation of a half-plane into a polygon—Transformation of the interior of a polygon into a half-plane—Exercises

CHAPTER VII

APPLICATION TO POTENTIAL PROBLEMS

119

Green's theorem—Hydrodynamics—Electrostatics—Current flow in a plane sheet—Conduction of heat—Exercises

CHAPTER VIII

APPLICATION TO THE THEORY OF ALTERNATING CURRENTS

127

Notation—Harmonic vectors—Vector representation of an alternating current—Impedance of an inductive coil—Impedance of a condenser—Impedances in series—Impedances in parallel—Impedance of parallel wires—Exercises

APPENDIX

SUGGESTIONS FOR FURTHER READING

134

INDEX

135

www.dbraulibrary.org.in

Downloaded from www.dbraulibrary.org.in

THE THEORY AND USE OF THE COMPLEX VARIABLE

CHAPTER I

COMPLEX NUMBERS AND THEIR REPRESENTATION

Graphical Representation of Real Numbers. One way of representing the real numbers graphically is to make use of points on a straight line $X'OX$, produced indefinitely far in both directions (Fig. 1). Taking any fixed point O on the line to represent zero and choosing a suitable unit of length, we may represent a positive number x_1 by a point P_1 on the line and to the right of O , such that OP_1 is x_1 units long, and a

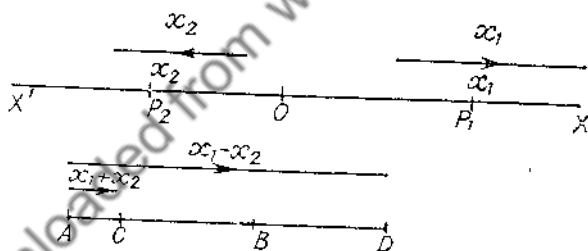

FIG. 1

negative number x_2 by a point P_2 to the left of O such that OP_2 is $-x_2$ units long. For example, the number (-3) is represented by a point on the left of O and 3 units distant from it. Then, to every real number, positive or negative, there corresponds one and only one point on the line and, conversely, to every point on the line there corresponds one and only one real number.

Another method is to represent the number by a *displacement* along the line, the positive number x_1 being represented by a displacement of x_1 units from left to right, and the negative

number x_2 being represented by a displacement of $-x_2$ units from right to left. Thus the number (-3) is represented by a displacement of 3 units from right to left.

The second method leads us to the idea of representing any real number x by a *vector*, either parallel to or lying in the line, the sense of the vector being from left to right for a positive number and from right to left for a negative number. The number of units of length of the vector is $\pm x$ according as x is positive or negative. We shall denote by $[x]$ the vector which represents x in this way. The modulus of x is defined to be the number of units of length of the vector and is denoted by $|x|$: this number is essentially positive.

Clearly, the vectors $[x]$ and $[-x]$ differ in sense but not in length, and so $|x| = |-x|$.

To represent the sum and difference of two real numbers x_1 (positive) and x_2 (negative), draw the vector $\overline{AB} = [x_1]$ and the vectors $\overline{BC} = [x_2]$ and $\overline{BD} = [-x_2]$. Then $\overline{AC} = [x_1 + x_2]$ and $\overline{AD} = [x_1 - x_2]$ (Fig. 1). Here \overline{AB} denotes the vector joining A , B in the sense from A to B .

The product x_1x_2 and the number x_1 have the same or opposite signs according as x_2 is positive or negative. Hence the vectors $[x_1x_2]$ and $[x_1]$ have the same sense if x_2 is positive, but are opposite in sense if x_2 is negative. The modulus of x_1x_2 is obviously equal to the product of the moduli of x_1 and x_2 , that is

$$|x_1x_2| = |x_1| \times |x_2|.$$

In particular, the effect of multiplying a number x by -1 is to reverse the direction of the vector $[x]$ without altering its length. We may therefore think of multiplication by -1 as an operation which rotates a vector through two right angles.

Purely Imaginary Numbers. Consider the quadratic equation $z^2 + 1 = 0$. No real value of z can satisfy the equation, for the square of a real number cannot be negative. If, then, the equation is satisfied when $z = i$, the number i cannot be real. We define i as the *imaginary unit*.

We shall assume that i obeys the laws of ordinary algebra; so that the equation may be written in the form

$$z^2 - i^2 = 0 \text{ or } (z - i)(z + i) = 0,$$

whence it is seen that the equation is also satisfied when $z = -i$. It follows that, if n is real, the equation $z^2 + n^2 = 0$ is satisfied by $z = \pm ni$.

A number of the form ni , where n is real, is called a *purely imaginary number*.

In introducing a new kind of number in this way we are following the precedent of the introduction of negative and fractional numbers in arithmetic, which were found to be necessary when the processes of subtraction and division were applied to the so-called *natural* numbers (positive integers).

For the graphical representation of the purely imaginary numbers we shall adopt methods which are exactly analogous

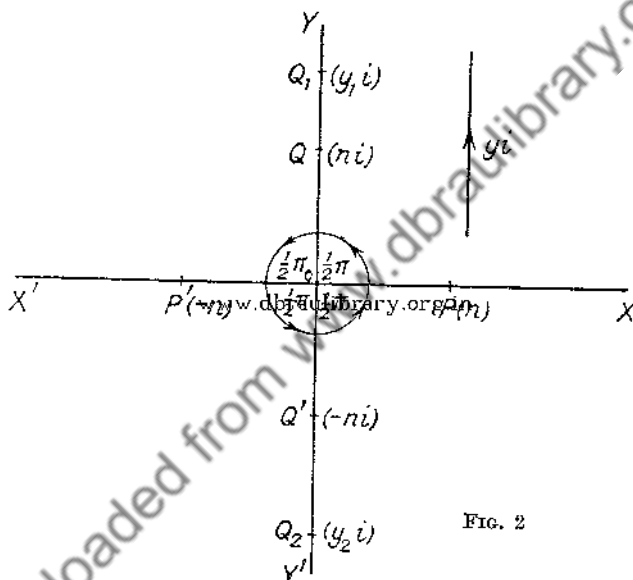

FIG. 2

to those already used for the real numbers. On an axis $Y'OY$, perpendicular to $X'OX$, represent $y_1 i$ (where y_1 is positive) by a point Q_1 , above O such that OQ_1 is y_1 units long, and represent $y_2 i$ (where y_2 is negative) by Q_2 below O such that OQ_2 is $-y_2$ units in length (Fig. 2).

The vector idea may also be used, and then the number yi is represented by a vector $[yi]$, either in or parallel to the line $Y'OY$, of length $\pm y$ units according as y is positive or negative, the sense being upwards if y is positive and downwards if y is negative. The length of the vector is called the *modulus* of yi and is denoted by $|yi|$. It follows that $|yi| = |y|$.

The imaginary unit i will then be represented by a unit vector in the positive sense.

If P is the point on $X'OX$ which represents the real number n , and if Q , on $Y'OY$, represents ni , the vectors $\overline{OP} = [n]$ and $\overline{OQ} = [ni]$ are equal in length and perpendicular in direction. The vector $[ni]$ could be obtained by rotating the vector $[n]$ through a right angle in the counter-clockwise sense, and this suggests that multiplication by i may be represented by the operation of turning a vector through a right angle. This is readily verified, for, if P' and Q' represent $-n$ and $-ni$, respectively,

$$\overline{OP'} = [-n] = [ni \times i] \text{ and } \overline{OQ'} = [-ni] = [-n \times i].$$

In Fig. 2 it has been assumed that n is positive; the reader can easily verify that the result holds good when n is negative.

Similarly, it may be shown that multiplication by $-i$ is equivalent to rotation of the vector through a right angle in the clockwise sense.

It follows that multiplication by i^2 or $(-i)^2$ is equivalent to rotation through two right angles in either sense, which, as we have already seen, is all the effect of multiplication by -1 .

Vectorial representation is thus consistent with the definition of i , viz. $i^2 = -1$; for multiplication twice by i is equivalent to multiplication by -1 .

Complex Numbers. The roots of the general quadratic equation

$$ax^2 + bx + c = 0,$$

where a, b, c , are real numbers, are $\{-b \pm \sqrt{(b^2 - 4ac)}\}/2a$. If the discriminant $b^2 - 4ac$ is positive or zero, these are real numbers and are of no particular interest, but, if the discriminant is negative, the roots are not real numbers. In this case, we can find a real number n such that $b^2 - 4ac = -4a^2n^2$, and, if we write $-b/2a = m$, the roots are $m \pm in$. Such numbers are said to be *complex*.

We shall take $x + iy$ to be the general complex number, x and y being real: x is defined as the *real part* and y as the *imaginary part* of the number.

It should be noted that the imaginary part of the number is itself real and is the coefficient of the imaginary unit i in the expression $x + iy$.

Purely real and purely imaginary numbers may be regarded

as special classes of the more general complex numbers, the former having zero for the imaginary part and the latter having zero for the real part. For zero, both real and imaginary parts vanish.

If $x + iy = 0$, then $x = y = 0$; otherwise the imaginary unit would be equal to $-x/y$, which is a real number, and this is impossible. It follows that two complex numbers which are equal are identical; for, if $x + iy = x' + iy'$, then

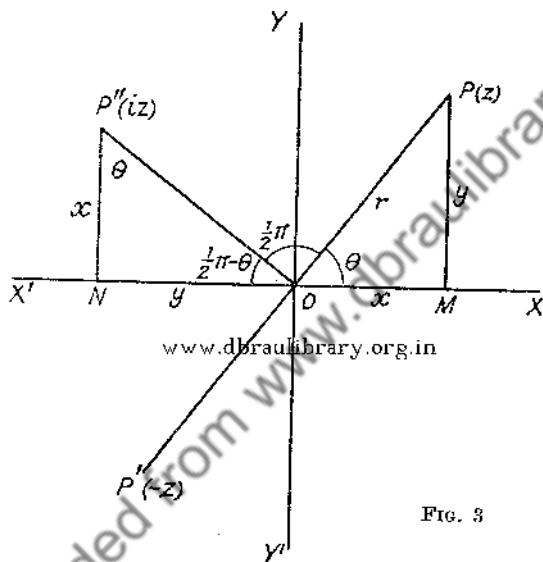

FIG. 3

$(x - x') + i(y - y') = 0$, and from the above, we have $x = x'$ and $y = y'$.

The complex numbers $x + iy$, $x - iy$, which have the same real parts and equal and opposite imaginary parts, are said to be *conjugate*. Their sum ($2x$) is real, their difference ($2iy$) is purely imaginary, and their product

$$(x + iy)(x - iy) = x^2 - (iy)^2 = x^2 + y^2$$

cannot be negative. The product would be zero only when $x = y = 0$. The conjugate of z is written \bar{z} .

It will be observed that the roots of the above quadratic are conjugate complex numbers when the discriminant is negative.

The Argand Diagram. In the plane of the perpendicular axes $X'OX$, $Y'OY$ (Fig. 3), plot the point P whose Cartesian

co-ordinates referred to these axes are (x, y) . Then we can take this point to represent the complex number $x + iy$. There is thus one and only one point in the plane which corresponds to the number. If we are given any point in the plane, we can find its co-ordinates (x, y) and hence construct the corresponding number $x + iy$. This number is called the *affix* of the point.

The diagram in which this representation is carried out is called the *Argand diagram*.

It is usual to write z for the number $x + iy$ and to refer to the plane as the z -plane. As before, the real numbers are then represented by points on the axis $X'OX$, called the *real axis*, and the purely imaginary numbers by points on the axis $Y'OY$, called the *imaginary axis*. The origin O represents zero.

With O as origin and OX as initial line, let (r, θ) be the polar co-ordinates of P : then

$$r = OP = \sqrt{(x^2 + y^2)},$$

$$\cos \theta = x/r, \quad \sin \theta = y/r$$

and

$$z = x + iy = r(\cos \theta + i \sin \theta).$$

The *modulus* of z (written $|z|$) is defined to be the length r , which is essentially positive and unique.

The *argument* or *amplitude* of z ($\arg z$ or $\text{amp } z$) is defined to be the angle θ and is infinitely many-valued since, if θ is any one determination of the angle XOP , any other determination is $\theta + 2k\pi$, where k is any integer, positive or negative.

As the argument of z is not unique, we define the *principal value* as that determination of the angle XOP which lies between the limits $-\pi$ and $+\pi$. The principal value is thus unique except when z is real and negative, in which case its principal argument is either $-\pi$ or $+\pi$, or when z is zero, in which case $\arg z$ is obviously indeterminate. *Unless the contrary is stated, we shall, in future, take "arg z " to mean the principal value.*

Vectorial Representation of a Complex Number. If r and θ are given, the point P is uniquely determined and we may represent the number z by a vector of length r in a direction which makes an angle θ with the positive direction of the real axis. In accordance with the notation used in connection with real numbers we shall denote such a vector by $[z]$. The vector need not be drawn from the origin but may be situated anywhere in the plane provided that it has the proper length and direction.

In practice it is convenient to employ both the point and the vector methods of representing a complex number, and not to use exclusively the one or the other.

In Fig. 3, the point P with co-ordinates (x, y) represents the number $z = x + iy$, and the vector \overline{OP} also represents the same number. The number $-z$ is represented by the point P' with co-ordinates $(-x, -y)$, and the corresponding vector is \overline{OP}' which is equal in length but opposite in sense to \overline{OP} .

The number $iz = i(x + iy) = -y + ix$ is represented by P'' . If $PM, P''N$ are drawn perpendicular to the real axis, we have $OM = NP''$ and $MP = ON$; so that the right-angled triangles $OMP, P''NO$ are congruent. It follows that the angle POP'' is a right angle.

Hence the multiplier -1 may be regarded as before as an operator which reverses the direction of a vector, and the multiplier i as an operator which turns a vector through a right angle in the positive sense. In neither case is there any change in the length of the vector.

EXAMPLE 1. In the Argand diagram, the numbers $1, i, -1, -i$ are represented by the points A, B, C, D , and the corresponding vectors are $\overline{OA}, \overline{OB}, \overline{OC}, \overline{OD}$, all of unit length, and their principal arguments are $0, \frac{1}{2}\pi, \pi, -\frac{1}{2}\pi$, respectively. Hence we may write

$$\begin{aligned} 1 &= 1(\cos 0 + i \sin 0), & i &= 1(\cos \frac{1}{2}\pi + i \sin \frac{1}{2}\pi), \\ -1 &= 1(\cos \pi + i \sin \pi), & -i &= 1(\cos -\frac{1}{2}\pi + i \sin -\frac{1}{2}\pi) \end{aligned}$$

The number $(1 + i)$ is represented by the point E with co-ordinates $(1, 1)$. Hence, $\overline{OE} = \sqrt{2}$ and the angle XOE is $\frac{1}{4}\pi$: so we have $(1 + i) = \sqrt{2}(\cos \frac{1}{4}\pi + i \sin \frac{1}{4}\pi)$.

EXAMPLE 2. Consider the locus of a point which represents a number z which varies so that $|z| = c$, where c is a real positive constant. The geometrical interpretation of this condition is that the distance of the point z from the origin is always equal to c . The locus is therefore a circle with its centre at the origin and radius c .

EXAMPLE 3. If z varies in such a way that $\arg z$ is constant, the locus of the point z is a straight line drawn from the origin.

EXAMPLE 4. If a point P represents the number $x + iy$, the point Q which represents the conjugate number $x - iy$ has co-ordinates $(x, -y)$ and is the image of P in the real axis. If $x + iy = z$, we denote the conjugate $x - iy$ by \bar{z} .

Addition and Subtraction. Let P and Q represent $z = x + iy$ and $z' = x' + iy'$, respectively (Fig. 4). Complete the parallelogram $OPRQ$. Since PR and OQ are equal and parallel, their projections on the axes of co-ordinates are equal, and so the co-ordinates of R are $(x + x', y + y')$. Therefore R represents the sum of the numbers represented by P and Q .

Vectorially, we have $\overline{OR} = \overline{OP} + \overline{OQ}$, which is the statement of the parallelogram law for the addition of two vectors.

In order to represent the difference of the two numbers, we may apply the above construction to the addition of the

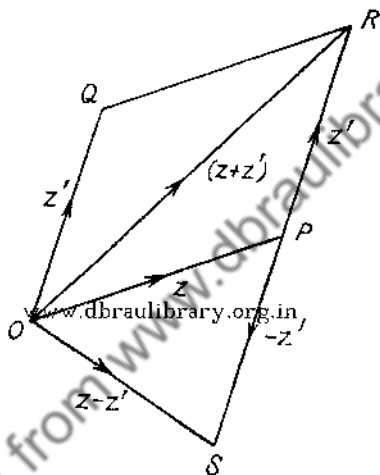

FIG. 4

numbers $x + iy$ and $-(x' + iy')$. Thus, if RP is produced to S so that $PS = PR$ in length, the vector \overline{OS} , which is equal and opposite to OQ , represents $-(x' + iy')$. Then

$$\overline{OS} = \overline{OP} + \overline{PS}$$

and therefore \overline{OS} represents $(x + iy) - (x' + iy')$.

It is not necessary to make use of the origin in the construction; for, if the vectors \overline{AB} and \overline{BC} have the same lengths and directions as \overline{OP} and \overline{OQ} , respectively, the triangles ABC , OPR are congruent and similarly placed, and therefore the vectors \overline{OR} and \overline{AC} are equivalent, and either may be taken to represent the sum.

Since the length of one side of a triangle cannot exceed the sum of the lengths of the other two sides, it follows that

$$OP + PR \geq OR \text{ and so } |z| + |z'| \geq |z + z'|.$$

This result may be stated: *the sum of the moduli of two complex numbers is greater than or equal to the modulus of their sum.*

Equality occurs only when the points O, P, R are collinear and P lies between O and R , i.e. when $\arg z = \arg z'$.

The construction may now be extended to give the sum of any number of complex terms. If vectors $\overline{AB}, \overline{BC}, \overline{CD}$ represent z_1, z_2, z_3 , respectively (Fig. 5), then \overline{AC} represents $z_1 + z_2$

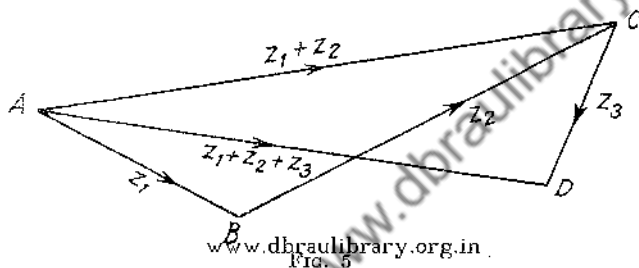

FIG. 5

and so \overline{AD} represents $z_1 + z_2 + z_3$. Since the length AD cannot exceed the sum of the lengths AB, BC, CD , we have

$$|z_1| + |z_2| + |z_3| \geq |z_1 + z_2 + z_3|.$$

Similarly, we may deal with the sum of n numbers and deduce that the sum of their moduli is greater than or equal to the modulus of their sum.

EXAMPLE 5. The vector which connects the points c and z in the Argand diagram, in the sense from c to z , represents the number $z - c$ and its length is $|z - c|$. If c is constant and z varies in such a way that $|z - c|$ is constant, the locus of the point z is a circle with its centre at the point c .

If c' is another constant and z varies so that

$$|z - c| + |z - c'| = \text{constant},$$

the locus of the point z is an ellipse whose foci are the points c, c' .

EXAMPLE 6. Let ABC be any triangle; then the vectors $\overline{BC}, \overline{CA}, \overline{AB}$ represent three complex numbers whose sum is zero. A similar result is true for the numbers represented by

vectors given by the sides of any closed polygon taken in order.

Multiplication and Division. The product and quotient of any two complex numbers are also complex numbers; for

$$(x + iy)(x' + iy') = xx' - yy' + i(xy' + x'y)$$

and

$$\frac{x + iy}{x' + iy'} = \frac{(x + iy)(x' - iy')}{(x' + iy')(x' - iy')}$$

$$= \frac{xx' + yy' + i(x'y - xy')}{x'^2 + y'^2}.$$

Notice how, in effecting the division, use is made of the conjugate of the denominator in order to obtain a new denominator which is purely real.

Now consider the same operations from the geometrical point of view.

Any two complex numbers z, z' may be written in the form

$$z = r(\cos \theta + i \sin \theta), z' = r'(\cos \theta' + i \sin \theta'),$$

where $r = |z|, r' = |z'|, \theta = \arg z, \theta' = \arg z'$.

Hence $z \times z' = rr'(\cos \theta + i \sin \theta)(\cos \theta' + i \sin \theta')$

$$= rr' \{(\cos \theta \cos \theta' - \sin \theta \sin \theta') + i(\sin \theta \cos \theta' + \cos \theta \sin \theta')\}$$

$$= rr' \{\cos(\theta + \theta') + i \sin(\theta + \theta')\}$$

Therefore $|zz'| = rr' = |z| \times |z'|$

and one determination of $\arg zz'$ is $\arg z + \arg z'$.

(It will be remembered that $\arg z$ is indeterminate to the extent of an added or subtracted multiple of 2π .)

Again

$$\frac{z}{z'} = \frac{r(\cos \theta + i \sin \theta)(\cos \theta' - i \sin \theta')}{r'(\cos \theta' + i \sin \theta')(\cos \theta' - i \sin \theta')}$$

$$= \frac{r\{(\cos \theta \cos \theta' + \sin \theta \sin \theta') + i(\sin \theta \cos \theta' - \sin \theta' \cos \theta)\}}{r'(\cos^2 \theta' + \sin^2 \theta')}$$

$$= (r/r') \{\cos(\theta - \theta') + i \sin(\theta - \theta')\}.$$

Therefore $|z/z'| = r/r' = |z|/|z'|$ and one determination of $\arg(z/z')$ is $\arg z - \arg z'$.

If the vectors which represent z and z' are parallel,

$$\arg z - \arg z'$$

is zero (when the vectors are in the same sense) or $\pm \pi$ (when the vectors are opposite in sense): in either event the value of

the quotient z/z' is purely real. Conversely, if z/z' is real, the vectors $[z]$ and $[z']$ are parallel.

If the vectors $[z]$ and $[z']$ are perpendicular, the arguments of z and z' differ by an odd multiple of $\frac{1}{2}\pi$ and the quotient is purely imaginary. The converse of the result is also true.

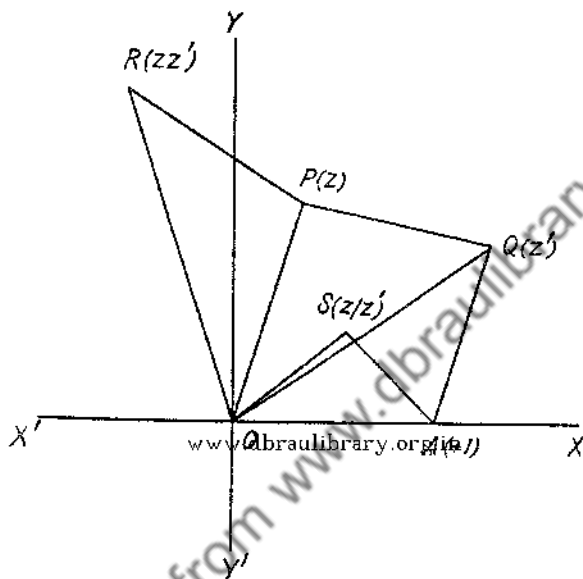

FIG. 6

In particular, the reciprocal of z is

$$1/z = (1/r) \{ \cos(-\theta) + i \sin(-\theta) \}$$

and so the principal arguments of a number and its reciprocal are equal in magnitude and opposite in sign.

Geometrical Constructions for the Product and the Quotient of Two Numbers. In Fig. 6, let the points A , P , Q respectively represent the numbers 1 , z , z' . Construct a triangle OPR which is directly similar to the triangle OAQ , the correspondence of vertices being in the order of mention.

Then, since $OR/OP = OQ/OA$, $OR = OP \cdot OQ$, as OA is of unit length. Also $\angle AOR = \angle AOP + \angle POR$

$$\begin{aligned} &= \angle AOP + \angle AOQ \\ &= \arg z + \arg z'. \end{aligned}$$

The point R therefore represents the number zz' .

Now make the triangle OAS directly similar to the triangle OQP . Then $OS/OA = OP/OQ$,

and $\angle AOS = \angle QOP = \arg z - \arg z'$.

The point S therefore represents the quotient z/z' .

EXAMPLE 7. Consider the constructions for z^2 and $1/z$. Taking z' in the above equal to z , the points P, Q coincide and the point R which represents z^2 is found by making the triangle OPR similar to the triangle OAP . The point S which represents $1/z$ is found by making the triangle OAS directly similar to the triangle OPA .

EXAMPLE 8. Let P and Q represent z and z' respectively and let any point R on the straight line PQ represent z'' . Since the vectors $\overline{PR}, \overline{RQ}$, which represent $z'' - z, z' - z''$, are in the same line (their senses being the same or opposite according as R divides QP internally or externally) the quotient $(z'' - z)/(z' - z'')$ is real and positive or negative according as R divides PQ internally or externally.

Hence $z'' - z = k(z' - z'')$ and so $z'' = (z + kz')/(1 + k)$ where the real constant k is positive for internal and negative for external division. Numerically, $k = PR/RQ$.

In particular, the middle point of PQ represents $\frac{1}{2}(z + z')$.

EXAMPLE 9. Suppose that the vertices of a triangle ABC represent a, b, c respectively. Then the middle point D of BC represents $\frac{1}{2}(b + c)$. The centroid G of the triangle divides AD in the ratio $2 : 1$ and so represents the number $\frac{1}{3}(a + b + c)$.

EXAMPLE 10. Two opposite vertices of a square represent $2, 4 + 4i$. Find the numbers represented by the other vertices.

If, in Fig. 7, A, C are the points $2, 4 + 4i$, the middle point E of AC is $3 + 2i$ (using Example 8 above) and the vector \overline{EC} represents $(4 + 4i) - (3 + 2i) = 1 + 2i$. Since $DE = EC$ and $\angle CED$ is a right angle, \overline{ED} represents $i(1 + 2i) = -2 + i$. Therefore D represents $(3 + 2i) + (-2 + i) = 1 + 3i$.

Similarly, \overline{EB} represents $-i(1 + 2i) = 2 - i$ and B represents $(3 + 2i) + (2 - i) = 5 + i$.

EXAMPLE 11. If z, z' are such that $|z + z'| = |z - z'|$, prove that iz/z' is real and that the straight line joining the points z and z' subtends a right angle at the origin. (*U.L.*)

If, in Fig. 8, P and Q represent z, z' respectively, the point Q' representing $-z'$ is found by producing QO to Q' so that

OQ, OQ' are equal in length. Then, as $\overline{Q'P}$ and \overline{QP} represent the numbers $z + z'$ and $z - z'$, which have equal moduli, $PQ = P'Q'$ and OP is the perpendicular bisector of QQ' . Hence

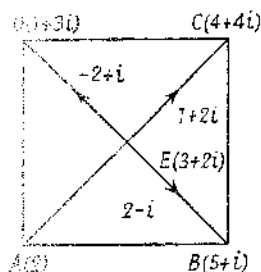

FIG. 7

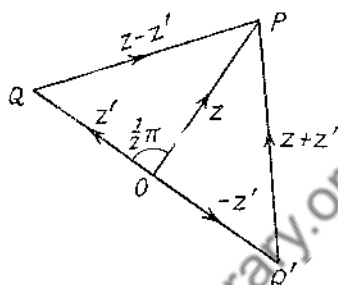

FIG. 8

$\arg iz/z' = \frac{1}{2}\pi - \angle QOP = 0$ and therefore iz/z' is real. Also the angle POQ , subtended by P and Q at the origin, is a right angle.

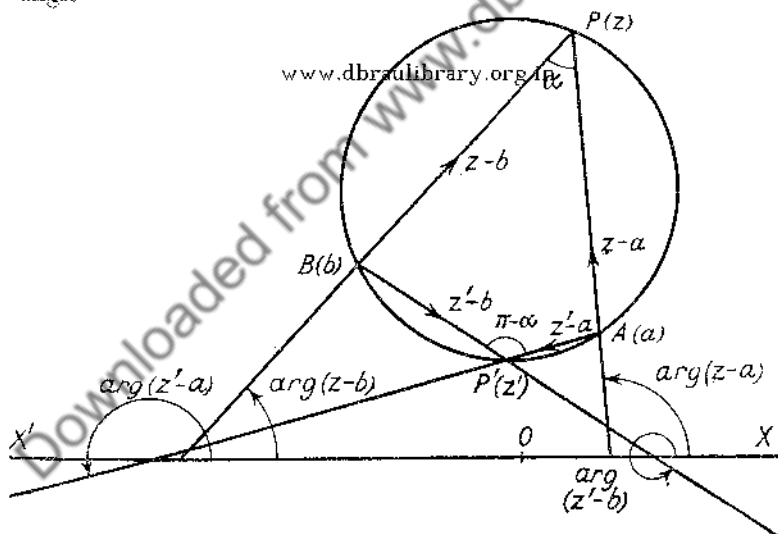

FIG. 9

EXAMPLE 12. In Fig. 9, A, B are two fixed points on a circle, P, P' are variable points on the two arcs AB . If the angle APB is α , then the angle $AP'B$ is $\pi - \alpha$. Let A, B, P, P' represent the numbers a, b, z, z' , respectively.

$$\begin{aligned} \text{Then } \arg(z-a)/(z-b) &= \arg(z-a) - \arg(z-b) \\ &= \alpha \pm \text{a multiple of } 2\pi \end{aligned}$$

$$\begin{aligned} \text{and } \arg(z'-a)/(z'-b) &= \arg(z'-a) - \arg(z'-b) \\ &= \alpha - \pi \pm \text{a multiple of } 2\pi. \end{aligned}$$

It follows that, if z varies so that $\arg(z-a)/(z-b)$ is constant, the locus of the point z is an arc of a circle which passes through the points a, b .

EXAMPLE 13. Suppose that z varies so that

$$|(z-a)/(z-b)| = k,$$

where k is constant. Then the point Q which represents z moves so that $AQ : BQ = k$ and its locus is a circle (unless $k = 1$ when the locus is the perpendicular bisector of AB). For different values of the constant k the circles form a family of coaxial circles having A and B as limiting points. They are orthogonal to the family of coaxial circles which pass through the points A and B (considered in Example 12 above).

EXAMPLE 14. If a, b, c, p, q, r are complex numbers represented by A, B, C, P, Q, R , respectively, prove that the necessary and sufficient condition for the triangles ABC, PQR to be directly similar is

$$a(q-r) + b(r-p) + c(p-q) = 0.$$

Show further that, if L, M, N are taken on AP, BQ, CR , so that

$$AL/LP = BM/MQ = CN/NR,$$

then the triangle LMN is directly similar to the other two.

If the triangles are directly similar, the angles BAC, QPR are equal and in the same sense, and also $AC/AB = PR/PQ$. These conditions are necessary and sufficient.

Consider the numbers $(c-a)/(b-a)$ and $(r-p)/(q-p)$. Their moduli are AC/AB and PR/PQ , respectively, and their arguments are the angles BAC, QPR measured in the same sense.

If, then, the triangles are directly similar, the above numbers have equal moduli and arguments and so are identical: conversely, if the numbers are equal, the conditions for direct similarity are satisfied.

Hence the necessary and sufficient conditions for the triangles to be directly similar may be written

$$(c - a)/(b - a) = (r - p)/(q - p)$$

or $a(q - r) + b(r - p) + c(p - q) = 0$. . . (i)

In the second part of the question, if we write k for the value of the equal ratios, then, from Example 8, L, M, N represent $(a + kp)/(1 + k), (b + kq)/(1 + k), (c + kr)/(1 + k)$, respectively. It is easily seen that, if these numbers are substituted for p, q , and r , the equation (i) is still satisfied. Consequently the triangle LMN is directly similar to the other two.

EXAMPLE 15. Two points P, Q , represent the roots of the equation $az^2 + 2bz + c = 0$ and two other points P', Q' represent the roots of

$$a'z^2 + 2b'z + c' = 0.$$

If R is the middle point of PQ , show that

$$\angle P'RP = \angle PRQ'$$

and $\angle RPP' = \angle RQ'P'$

if $ac' + ca' = 2bb'$. (U.L.)

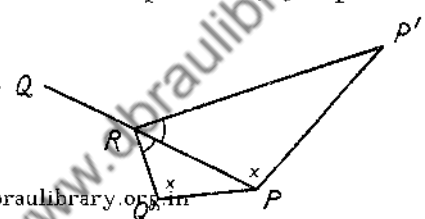

FIG. 10

We have to show that the triangles $PRP', Q'RP$ are directly similar if the condition is satisfied.

Let P, Q, P', Q' represent p, q, p', q' , respectively (Fig. 10). Then R represents $\frac{1}{2}(p + q) = -b/a$. From Example 14, it follows that the triangles $PRP', Q'RP$ are directly similar if

$$p[(-b/a) - p] - (b/a)(p - q') + p'[q' + (b/a)] = 0.$$

On multiplying by $-a$ this becomes

$$ap^2 + 2bp - b(p' + q') - ap'q' = 0.$$

Since $ap^2 + 2bp + c = 0, p' + q' = -2b'/a',$ and $p'q' = c'/a',$ the condition reduces to

$$c + 2b(-b'/a') + (ac'/a') = 0 \text{ or } ac' + ca' = 2bb'.$$

EXAMPLE 16. P represents z in the Argand diagram and Q represents z^2 . If P lies on the circle of unit radius with its centre at the point $+1$, show geometrically that $|z^2 - z| = |z|$ and that $\arg(z - 1) = \arg z^2 = \frac{2}{3} \arg(z^2 - z)$. Find the polar equation of the locus of Q . (U.L.)

In Fig. 11 let A represent $+1$ and let $\arg z = \frac{1}{2}\theta$. Make the triangle OPQ directly similar to OAP . Then Q is the point z^2 since

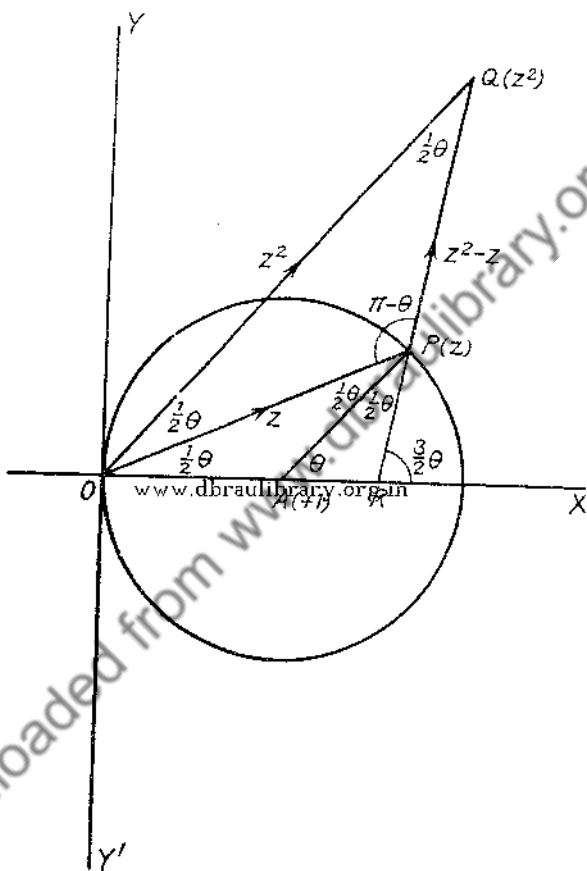

FIG. 11

$\angle XOQ = \angle AOP + \angle POQ = \theta$ and $OQ : OP = OP : OA$, whence $OQ = |z^2|$.

If P lies on the given circle, AP is of unit length and the two triangles are isosceles. The vectors \overline{OP} ($= z$) and \overline{PQ} ($= z^2 - z$) are equal in length, i.e. $|z^2 - z| = |z|$.

$$\begin{aligned} \text{also } \arg(z^2 - z) &= \angle XRP \\ &= \angle XAP + \angle APR \\ &= 3\theta/2, \end{aligned}$$

whence $\theta = \arg z^2 = (2/3) \arg(z^2 - z) = \arg(z - 1)$.

If $OQ = r$, we have

$$r = |z|^2 = (2 \cos \frac{1}{2}\theta)^2 = 2(1 + \cos \theta);$$

∴ the locus of Q is the cardioid given by the polar equation

$$r = 2(1 + \cos \theta).$$

EXAMPLE 17. If the vertices of an equilateral triangle represent a, b, c , prove that

$$a^2 + b^2 + c^2 - bc - ca - ab = 0.$$

The vectors which represent the numbers $b - c, c - a, a - b$ are the sides of the triangle taken in order. These are equal in length and their arguments may be expressed in the form $\theta, \theta + 2\pi/3, \theta + 4\pi/3$, or $\theta, \theta - 2\pi/3, \theta - 4\pi/3$, according to the sense of description of the triangle.

In either case, $(b - c)/(c - a) = e^{i(\theta + 2\pi/3)}/e^{i\theta} = e^{i2\pi/3} = \omega$, since the numbers on the left and right of this equation both have unit modulus and the same argument ($\pm 2\pi/3$).

On cross-multiplying, the equation becomes

$$(b - c)(a - b) = (c - a)^2,$$

which reduces to the required condition.

The converse of this proposition is also true and is left as an exercise for the reader.

EXERCISES

1. Mark on a diagram the points which represent the numbers $2 + 3i, 1/(2 + 3i), (1 + i)/(1 - i), (1 + i)^2/(1 - i)^2, (1 + 2i)(5 + 7i)(3 + 4i)^{-1}(6 + i)^{-1}$.
2. Prove that the points $a + ib, 0, 1/(-a + ib)$ lie on a straight line and that the points $a + ib, 1/(-a + ib), -1, \pm 1$ lie on a circle.
3. A, B, C are the vertices of an equilateral triangle. If A represents $5 + 7i$ and the centroid of the triangle represents $1 + 4i$, find the numbers represented by B and C .
4. If z_1, z_2, z_3 are complex numbers such that their representative points are collinear, prove that they satisfy a relation of the form $az_1 + bz_2 + cz_3 = 0$, where a, b, c are real and $a + b + c = 0$.
5. Six points are the vertices of a regular hexagon $ABCDEF$, the inside of the hexagon being on the left when the perimeter is described

in the order given. If A is the origin and C represents $3 + 4i$, find the numbers represented by B, D, E, F . (U.L.)

6. Two complex numbers are represented by points marked in an Argand diagram. Construct the point that represents their product. Carry out the construction for the numbers $(5/4) + 3i, -3 + (5i/4)$. (U.L.)

7. Three complex numbers u, v, w , such that $v^2 = wu$, are represented by the points P, Q, R , respectively. If R is joined to the origin O and RO is produced to P' so that $OP' = OP$ in length, prove that the circle which passes through the points R, Q, P' passes also through the point representing $-v$. Prove also that P' represents $-w | u/w |$. (U.L.)

8. Show that the straight lines joining the points representing the numbers a, b and c, d are parallel if $(a - b)/(c - d)$ is purely real, and perpendicular if this fraction is purely imaginary.

Two adjacent vertices of a square are the origin and the point $2 + 3i$, and the figure lies entirely above the real axis. Find the numbers represented by the remaining vertices.

9. P and Q are two points which represent complex numbers p, q , respectively. If k is a real constant, show how to find the point which represents $p + k(q - p)$.

The internal and external bisectors of the angle subtended by PQ at the origin meet PQ at the points L, E , respectively, and M is the mid-point of LE . If

$$p = \cos(\pi/6) + i \sin(\pi/6)$$

and

$$q = \cos(\pi/3) + i \sin(\pi/3),$$

show that L represents $(1 + \sqrt{3})(1 + i)/3$ and find the number represented by M . (U.L.)

10. The numbers p, q, r are represented by the vertices P, Q, R of an isosceles triangle, the angles at Q and R being each $(\pi - \alpha)/2$. Prove that $(r - q)^2 = 4 \sin^2 \frac{1}{2} \alpha \cdot (r - p)(p - q)$.

11. Show that the points $-1, +1, i\sqrt{3}$, are the vertices of an equilateral triangle. By using the result of Example 14, worked on p. 14, deduce the condition that the triangle, whose vertices are the points a, b, c , should be equilateral.

12. In the plane of the complex variable z , regular hexagons are described to have for one side the line joining the points $-1, +1$. Find the values of z represented by the remaining eight vertices.

The whole plane is partitioned into equal cells, each cell being a regular hexagon, and z_1, z_2 are the numbers represented by two adjacent vertices of one cell. Prove that, if z, z' are the numbers represented by the points in which two opposite sides of one of the cells are met by a line perpendicular to them, then

$$\text{either } z' = z \pm \frac{1}{2}(3 + i\sqrt{3})(z_2 - z_1),$$

$$\text{or } z' = z \pm \frac{1}{2}(3 - i\sqrt{3})(z_2 - z_1),$$

$$\text{or else } z' = z \pm i\sqrt{3}(z_2 - z_1).$$

(U.L.)

13. Show that, if $(z_1 - z_2)/(Z_1 - Z_2) = (z_2 - z_3)/(Z_2 - Z_3)$, the points z_1, z_2, z_3 and Z_1, Z_2, Z_3 are the vertices of two similar triangles.

Three similar triangles BCA', CAB', ABC' are drawn on the sides of a triangle ABC , the correspondence of vertices being indicated by the

order of mention, with A', B', C' lying on the sides of BC, CA, AB remote from A, B, C . Show that the triangles $ABC, A'B'C'$ have the same centroid. (U.L.)

14. If A, B, C are the vertices of any triangle and BC, CA, AB are produced to A', B', C' , where $AB' = CA, BC' = AB, CA' = BC$, show that the triangles $A'B'C', ABC$ cannot be similar (correspondence of points being in the order here given) unless ABC is equilateral. (U.L.)

15. If a, b are complex constants and z varies so that $\arg(z - a)(z - b)$ is constant, prove that the point z moves on a branch of a rectangular hyperbola which passes through the points a and b .

16. O is the origin and U represents $+1$. If P represents a variable number z , prove that PO is perpendicular to PU if the real part of $(z - 1)/z$ is zero. Deduce that, if $z = 1/(1 + it)$ where t is a variable real number, then the point representing z describes a circle of unit diameter. (U.L.)

17. If $w = z^2$, show in an Argand diagram the path traced out by the point w as the point z describes the rectangle whose vertices are the points $\pm a, \pm a + ia$, where a is real. (U.L.)

18. Interpret geometrically the following loci—

$$(i) |z + 1|^2 - |z - 1|^2 = 2;$$

$$(ii) \arg\{(z - 1)/(z + 1)\} = \frac{1}{2}\pi. \quad (U.L.)$$

19. Two complex numbers z, w are related by the equation $w(z + 1) = 2(z - 4)$. Express in the form $a + ib$ the values of w when $z = i$ and $-2 + 3i$. Indicate the positions of the corresponding points in a diagram.

20. In an Argand diagram the points P, Q represent w and z , where $w(z + 1) = z - 1$. Find the locus of Q if P describes a line through the origin inclined at an angle α to the x -axis and show that if Q describes a circle of a coaxial system whose limiting points are $(1, 0), (-1, 0)$, then P describes a circle whose centre is the origin. (U.L.)

21. Prove that the necessary and sufficient condition that the points z_1, z_2, z_3, z_4 may be concyclic is that $(z_3 - z_1)(z_4 - z_2)/(z_3 - z_2)(z_4 - z_1)$ should be real.

22. Show that the affix of the centroid of particles m_1, m_2, m_3, \dots placed at the points z_1, z_2, z_3, \dots is

$$(m_1 z_1 + m_2 z_2 + m_3 z_3 + \dots)/(m_1 + m_2 + m_3 + \dots).$$

23. If $P = (d - a)/(b - c)$, $Q = (d - b)/(c - a)$, $R = (d - c)/(a - b)$, prove that

$$QR + RP + PQ + 1 \equiv 0.$$

Taking a, b, c, d to be the complex numbers represented by A, B, C, D in the Argand diagram, show that, if DA, DB be respectively perpendicular to BC, CA , then DC is perpendicular to AB ; and derive from the above identity the relation

$$BC \cdot BD \cdot CD + CA \cdot CD \cdot AD + AB \cdot AD \cdot BD = BC \cdot CA \cdot AB,$$

the triangle ABC being acute angled. (U.L.)

24. $ABCD$ is a rhombus and $AC = 2BD$. If B, D represent $1 + 3i$ and $-3 + i$, find the numbers represented by A and C . (U.L.)

CHAPTER II

DE MOIVRE'S THEOREM

Theory of Equations. If

$$f(z) \equiv a_0 z^n + a_1 z^{n-1} + a_2 z^{n-2} + \dots + a_n,$$

where n is a positive integer and the coefficients $a_0, a_1, a_2, \dots, a_n$ are real or complex numbers independent of z , $f(z)$ is a *polynomial* and the equation $f(z) = 0$ is defined as an algebraic equation of the n th degree. Any value of z which satisfies this equation is said to be a *root* of the equation or a *zero* of the polynomial $f(z)$. According to the fundamental theorem of algebra (which will not be proved here), every such equation has at least one root, which is either real or complex. If we assume the truth of this theorem, it is easy to show that an equation of the n th degree has n and only n roots.

Suppose that $f(z)$ vanishes when $z = \alpha_1$ where α_1 is either real or complex. From the factor theorem of elementary algebra, it follows that $(z - \alpha_1)$ is a factor of $f(z)$ and we may write

$$f(z) \equiv (z - \alpha_1)F(z),$$

where $F(z)$ is a polynomial of degree $n - 1$, and must itself vanish for some value of z , say α_2 . Therefore $F(z)$ must have $(z - \alpha_2)$ as a factor, the other factor being a polynomial of degree $n - 2$.

Continuing in this way, we see that we may write

$$f(z) \equiv a_0(z - \alpha_1)(z - \alpha_2)(z - \alpha_3) \dots (z - \alpha_n).$$

Clearly, $f(z)$ vanishes only when z has one of the values $\alpha_1, \dots, \alpha_n$, and the proposition is proved.

If we write out the product of the factors in the above expression of the polynomial, we obtain the identity

$$\begin{aligned} a_0 z^n + a_1 z^{n-1} + a_2 z^{n-2} + \dots + a_n \\ \equiv a_0 [z^n - P_1 z^{n-1} + P_2 z^{n-2} - \dots + (-1)^r P_r z^{n-r} \\ + \dots + (-1)^n P_n], \end{aligned}$$

where P_r denotes the sum of the products r at a time of the n roots $\alpha_1, \alpha_2, \dots, \alpha_n$.

Identifying coefficients, we have

$$P_1 = -a_1/a_0, P_2 = a_2/a_0, \dots, P_r = (-1)^r a_r/a_0, \\ \dots, P_n = (-1)^n a_n/a_0.$$

The roots $\alpha_1, \alpha_2, \dots, \alpha_n$ of the equation need not be distinct: if r of them are equal to α_1 and all the others are different from α_1 , we say that α_1 is a multiple root which occurs r times, or more briefly, α_1 is an r -ple root. When this is the case

$$f(z) \equiv a_0(z - \alpha_1)^r \phi(z),$$

where $\phi(z)$ is a polynomial of degree $n - r$ which does not vanish when $z = \alpha_1$.

Differentiating with respect to z and denoting derivatives by means of dashes, we have

$$f'(z) \equiv a_0(z - \alpha_1)^{r-1} [(z - \alpha_1)\phi'(z) + r\phi(z)].$$

The expression in square brackets on the right-hand side does not vanish when $z = \alpha_1$, and so it follows that $f'(z)$ has a factor $(z - \alpha_1)^{r-1}$. Thus if $f(z)$ has α_1 as an r -ple root, $f'(z)$ has α_1 as an $(r - 1)$ -ple root.

Further, if $f(z) = 0$ has no repeated root, then its roots are not among those of the derived equation $f'(z) = 0$.

We have thus a means of finding out whether or not a given equation has multiple roots. All we need do is to examine $f(z)$ and its derived function $f'(z)$ for a common factor: if there is no common factor which is a function of z , there are no multiple roots, but, if there is a common factor of the form $(z - \alpha)^{r-1}$, then α is an r -ple root.

For example, it can be seen in this way that the binomial equation $z^n - c = 0$, where c is not zero, has n distinct roots, since the derived equation $nz^{n-1} = 0$ is satisfied only by $z = 0$ and this value of z does not satisfy the given equation.

IF THE COEFFICIENTS ARE REAL, COMPLEX ROOTS OCCUR IN CONJUGATE PAIRS. The results obtained above are true, whatever may be the values, real or complex, of the coefficients a_0, a_1, \dots, a_n . If, as is usually the case, these coefficients are all real, it can be shown that complex roots (if any) occur in conjugate pairs.

If we give z a complex value $\lambda + i\mu$, the polynomial has the value

$$f(\lambda + i\mu) \equiv a_0(\lambda + i\mu)^n + a_1(\lambda + i\mu)^{n-1} + \dots + a_n \\ \equiv P + iQ,$$

where P and Q are real.

Since even powers of $i\mu$ are real and odd powers are purely imaginary, P contains only even powers of μ while Q contains only odd powers, provided, of course, that the coefficients a are all real. If the sign of μ is changed, P is unaltered but Q changes sign. Hence

$$f(\lambda - i\mu) \equiv P - iQ.$$

If $\lambda + i\mu$ is a root of the equation, P and Q both vanish and therefore $f(\lambda - i\mu) = 0$, i.e. complex roots occur in conjugate pairs. Consequently, the total number of complex roots of an equation having real coefficients must be even (or zero). If the degree of the equation is odd, the number of real roots must be odd also.

If the polynomial has complex zeros, the factors corresponding to these can be combined to give quadratic factors with real coefficients, since

$$(z - \lambda - i\mu)(z - \lambda + i\mu) = (z - \lambda)^2 + \mu^2.$$

Such a polynomial can be expressed therefore as a product of linear factors like $(z - \alpha)$, in which α is real, and of quadratic factors like $z^2 + bz + c$, in which b and c are real.

E.g. $z^3 - 1 = (z - 1)(z^2 + z + 1)$
and $z^6 + 1 = (z^2 + 1)(z^2 - z\sqrt{3} + 1)(z^2 + z\sqrt{3} + 1).$

De Moivre's Theorem. If θ_1, θ_2 be any two angles, we have, as on p. 10,

$$\begin{aligned} &(\cos \theta_1 + i \sin \theta_1)(\cos \theta_2 + i \sin \theta_2) \\ &= \cos \theta_1 \cos \theta_2 - \sin \theta_1 \sin \theta_2 \\ &\quad + i(\sin \theta_1 \cos \theta_2 + \cos \theta_1 \sin \theta_2) \\ &= \cos(\theta_1 + \theta_2) + i \sin(\theta_1 + \theta_2). \end{aligned}$$

Multiplying by a third factor of the same type, we have

$$\begin{aligned} &(\cos \theta_1 + i \sin \theta_1)(\cos \theta_2 + i \sin \theta_2)(\cos \theta_3 + i \sin \theta_3) \\ &= [\cos(\theta_1 + \theta_2) + i \sin(\theta_1 + \theta_2)][\cos \theta_3 + i \sin \theta_3] \\ &= \cos(\theta_1 + \theta_2 + \theta_3) + i \sin(\theta_1 + \theta_2 + \theta_3). \end{aligned}$$

Continuing in this way, we obtain the result for n factors —

$$\begin{aligned} &(\cos \theta_1 + i \sin \theta_1)(\cos \theta_2 + i \sin \theta_2) \dots (\cos \theta_n + i \sin \theta_n) \\ &= \cos(\theta_1 + \theta_2 + \dots + \theta_n) + i \sin(\theta_1 + \theta_2 + \dots + \theta_n). \end{aligned}$$

If we put $\theta_1 = \theta_2 = \dots = \theta_n = \theta$, this result becomes

$$(\cos \theta + i \sin \theta)^n = \cos n\theta + i \sin n\theta,$$

where n is a positive integer.

We shall now show that this result is still true when n is any rational number, positive or negative.

Assume that α is such that

$$(\cos \theta + i \sin \theta)^{p/q} = \cos \alpha + i \sin \alpha,$$

where p and q are positive integers.

Then $(\cos \theta + i \sin \theta)^p = (\cos \alpha + i \sin \alpha)^q$

i.e. $\cos p\theta + i \sin p\theta = \cos q\alpha + i \sin q\alpha$

(from the result above). On equating the real and imaginary parts, we see that our initial assumption is justified if $\alpha = p\theta/q$. This is not the only possible value of α ; the other values will be considered later (p. 25).

One value of $(\cos \theta + i \sin \theta)^{p/q}$ is therefore

$$\cos \left(\frac{p\theta}{q}\right) + i \sin \left(\frac{p\theta}{q}\right).$$

Now suppose that m is any negative integer or fraction. Since

$$(\cos \theta + i \sin \theta)(\cos \theta - i \sin \theta) = \cos^2 \theta + \sin^2 \theta = 1,$$

we have

$$\begin{aligned} (\cos \theta + i \sin \theta)^m &= (\cos \theta - i \sin \theta)^{-m} \\ &= [\cos(-\theta) + i \sin(-\theta)]^{-m} \\ &= \cos m\theta + i \sin m\theta, \end{aligned}$$

by application of the above results, since $-m$ is positive.

We may now state de Moivre's theorem in its general form thus: *one value of $(\cos \theta + i \sin \theta)^n$ is $\cos n\theta + i \sin n\theta$, where n is any rational real number.*

Deductions from de Moivre's Theorem. Let n be a positive integer and write c, s, t for $\cos \theta, \sin \theta, \tan \theta$. Then, by the binomial theorem

$$\begin{aligned} \cos 2n\theta + i \sin 2n\theta &= (c + is)^{2n} \\ &= c^{2n} + {}^{2n}C_1 c^{2n-1} is + {}^{2n}C_2 c^{2n-2} (is)^2 \\ &\quad + \dots + (is)^{2n}. \end{aligned}$$

Equating real and imaginary parts, we have

$$\begin{aligned}\cos 2n\theta &= c^{2n} - {}^{2n}C_2 c^{2n-2} s^2 + {}^{2n}C_4 c^{2n-4} s^4 - \dots + (-s^2)^n \\ \sin 2n\theta &= {}^{2n}C_1 c^{2n-1} s - {}^{2n}C_3 c^{2n-3} s^3 + {}^{2n}C_5 c^{2n-5} s^5 \\ &\quad - \dots + (-1)^{n-1} {}^{2n}C_{2n-1} c s^{2n-1}.\end{aligned}$$

Similarly,

$$\begin{aligned}\cos (2n+1)\theta + i \sin (2n+1)\theta &= (c + is)^{2n+1} \\ &= c^{2n+1} + {}^{2n+1}C_1 c^{2n} i s \\ &\quad + {}^{2n+1}C_2 c^{2n-1} (is)^2 \\ &\quad + \dots + (is)^{2n+1}\end{aligned}$$

and hence

$$\begin{aligned}\cos (2n+1)\theta &= c^{2n+1} - {}^{2n+1}C_2 c^{2n-1} s^2 + {}^{2n+1}C_4 c^{2n-3} s^4 \\ &\quad - \dots + (-1)^n {}^{2n+1}C_{2n} c s^{2n} \\ \sin (2n+1)\theta &= {}^{2n+1}C_1 c^{2n} s - {}^{2n+1}C_3 c^{2n-2} s^3 + {}^{2n+1}C_5 c^{2n-4} s^5 \\ &\quad - \dots + (-1)^n s^{2n+1}.\end{aligned}$$

By division, we obtain

$$\begin{aligned}\tan 2n\theta &= \frac{{}^{2n}C_1 c t - {}^{2n}C_3 c^3 t^3 + {}^{2n}C_5 c^5 t^5 - \dots + (-1)^{n-1} {}^{2n}C_{2n-1} t^{2n-1}}{1 - {}^{2n}C_2 c^2 t^2 + {}^{2n}C_4 c^4 t^4 - \dots + (-1)^n t^{2n}} \\ &= \frac{\text{www.dreamtost.in}}{\text{www.dreamtost.in}}\end{aligned}$$

$$\begin{aligned}\tan (2n+1)\theta &= \frac{{}^{2n+1}C_1 c t - {}^{2n+1}C_3 c^3 t^3 + {}^{2n+1}C_5 c^5 t^5 - \dots + (-1)^n t^{2n+1}}{1 - {}^{2n+1}C_2 c^2 t^2 + {}^{2n+1}C_4 c^4 t^4 - \dots + (-1)^n {}^{2n+1}C_{2n} t^{2n}}\end{aligned}$$

THE n TH ROOTS OF UNITY. We shall now apply de Moivre's theorem to evaluate the n th roots of unity, n being a positive integer. In other words, we shall solve the equation $z^n = 1$ which has been shown (p. 21) to have n distinct roots.

Suppose that the equation is satisfied when

$$z = r(\cos \alpha + i \sin \alpha).$$

Then we must have

$$r^n(\cos \alpha + i \sin \alpha)^n = r^n(\cos n\alpha + i \sin n\alpha) = 1,$$

whence $r = 1$, $\cos n\alpha = 1$ and $\sin n\alpha = 0$. These conditions are satisfied if $n\alpha = 2k\pi$, where k is zero or any integer. Taking $k = 0, 1, 2, 3, \dots, n-1$ we obtain the n numbers

$$\begin{aligned}1, \cos (2\pi/n) + i \sin (2\pi/n), \cos (4\pi/n) + i \sin (4\pi/n), \\ \dots, \cos [(2n-2)\pi/n] + i \sin [(2n-2)\pi/n],\end{aligned}$$

all of which satisfy the equation.

No two of these numbers are equal because the difference between any two of the values of the angle α is less than 2π . The numbers are therefore the n distinct values of the n th roots of unity.

In the Argand diagram, the n th roots of unity are represented by the vertices of a regular n -gon inscribed in the circle $|z| = 1$ and having one vertex on the positive branch of the real axis.

If n is even, there are two real n th roots, viz. 1 and -1 , which are given by taking $k = 0$ and $\frac{1}{2}n$ respectively. The remaining $n - 2$ roots are complex. If n is odd, the only real root is 1.

Putting $\omega = \cos(2\pi/n) + i \sin(2\pi/n)$, we can write the roots in the form $1, \omega, \omega^2, \dots, \omega^{n-1}$, whence it is seen that they form a geometric progression with common ratio ω . Their sum is given by the usual formula, viz. $(1 - \omega^n)/(1 - \omega)$ and this vanishes since $\omega^n = 1$. (The same result follows more simply from the fact that the equation $z^n - 1 = 0$ contains no term in z^{n-1} and so the sum of the roots is zero.)

THE n TH ROOTS OF ANY COMPLEX NUMBER. If c is any number, in general complex, its n th roots are the n values of z which satisfy the equation $z^n = c$. If z_1 is any one of the roots of this equation, then λz_1 is also a root if $\lambda^n z_1^n = c$, and therefore $\lambda^n = 1$, i.e. λ is an n th root of unity. Thus we can give λ the n values $1, \omega, \omega^2, \dots, \omega^{n-1}$.

In order to find a suitable value of z_1 , we express c in the form $|c|(\cos \theta + i \sin \theta)$ and assume that

$$z_1 = R(\cos \phi + i \sin \phi).$$

We then make

$$R^n(\cos n\phi + i \sin n\phi) = |c|(\cos \theta + i \sin \theta),$$

and this condition is satisfied when $R = |c|^{1/n}$ and $\phi = \theta/n$. Here $|c|^{1/n}$ denotes the real positive n th root of the positive number $|c|$, and θ may be any determination of $\arg c$, but it is usually most convenient to take the principal value. The n th roots of c are thus

$$z_1, \omega z_1, \omega^2 z_1, \dots, \omega^{n-1} z_1,$$

where

$$z_1 = |c|^{1/n}[\cos(\theta/n) + i \sin(\theta/n)].$$

It will be observed that these numbers form a geometric progression of which the sum is zero. Inserting the value of ω

and using the result on p. 10, we obtain the n th roots by giving k the values $0, 1, 2, 3, \dots, n-1$ in the expression

$$|c|^{1/n} \{ \cos [(\theta + 2k\pi)/n] + i \sin [(\theta + 2k\pi)/n] \}.$$

In the Argand diagram these numbers are represented by the points $Q_0, Q_1, Q_2, \dots, Q_{n-1}$ on the circle $|z| = |c|^{1/n}$ and such that the angle XOQ_k is $(\theta + 2k\pi)/n$. The points Q are thus the vertices of a regular polygon of n sides inscribed in the circle.

EXAMPLE 1. The cube roots of -1 . We have here

$$R^3(\cos 3\phi + i \sin 3\phi) = -1 = \cos \pi + i \sin \pi,$$

whence $R = 1$ and we can take $\phi = \pi/3$.

Also $\omega = \cos (2\pi/3) + i \sin (2\pi/3)$ and the cube roots of -1 are

$$\begin{aligned} & \cos (\pi/3) + i \sin (\pi/3), \omega[\cos (\pi/3) + i \sin (\pi/3)], \\ & \omega^2[\cos (\pi/3) + i \sin (\pi/3)] \\ \text{i.e. } & \cos (\pi/3) + i \sin (\pi/3), \cos \pi + i \sin \pi = -1, \\ & \cos (5\pi/3) + i \sin (5\pi/3). \end{aligned}$$

The numerical values are $\frac{1}{2}(1 + i\sqrt{3})$, -1 , $\frac{1}{2}(1 - i\sqrt{3})$.

EXAMPLE 2. The cube roots of $1 + i$. On plotting the point representing the number $1 + i$ in the Argand diagram, it is seen that $|1 + i| = \sqrt{2}$ and $\arg (1 + i) = \pi/4$. Hence the three cube roots are

$$\begin{aligned} z_1 &= 2^{1/6}[\cos (\pi/12) + i \sin (\pi/12)], \\ \omega z_1 &= 2^{1/6}[\cos (\pi/12) + i \sin (\pi/12)] [\cos (2\pi/3) + i \sin (2\pi/3)] \\ &= 2^{1/6}[\cos (3\pi/4) + i \sin (3\pi/4)], \\ \text{and} \\ \omega^2 z_1 &= 2^{1/6}[\cos (\pi/12) + i \sin (\pi/12)] [\cos (4\pi/3) + i \sin (4\pi/3)] \\ &= 2^{1/6}[\cos (17\pi/12) + i \sin (17\pi/12)]. \end{aligned}$$

EXAMPLE 3. Obtain with the aid of tables the values of $(3 - 4i)^{1/3}$.

From the Argand diagram (Fig. 12) it is seen that $\arg (3 - 4i) = -\theta$, where θ is the positive acute angle such that $\sin \theta = 0.8$, i.e. $\theta = 53^\circ 8'$. Hence

$$3 - 4i = 5[\cos (-\theta/3) + i \sin (-\theta/3)].$$

and, from four-figure tables, the cube roots are

$$5^{1/3}[\cos(-\theta/3) + i \sin(-\theta/3)] = 5^{1/3}(\cos 17^\circ 43' - i \sin 17^\circ 43') \\ = 1.629 - 0.5204i,$$

$$5^{1/3}[\cos(120^\circ - 17^\circ 43') + i \sin(120^\circ - 17^\circ 43')] \\ = -0.3638 + 1.670i$$

$$\text{and } 5^{1/3}[\cos(240^\circ - 17^\circ 43') + i \sin(240^\circ - 17^\circ 43')] \\ = -1.265 - 1.150i.$$

As a check on the numerical work, we note that the sum of the three roots is zero.

EXAMPLE 4. Prove that

$$\cot^2(\pi/7) + \cot^2(2\pi/7) \\ + \cot^2(3\pi/7) = 5.$$

The equation $\tan 7\theta = 0$ is satisfied if $7\theta = n\pi$, where n is zero or any integer. From the result obtained on p. 24 we have,

$$\tan 7\theta = (7t - 7C_3t^3 + 7C_5t^5 - t^7)/(1 - 7C_2t^2 + 7C_4t^4 - 7C_6t^6),$$

where $t = \tan \theta$, and from this it follows that $\tan 7\theta$ vanishes when $t = 0$ or when t satisfies the equation

$$7 - 7C_3t^2 + 7C_5t^4 - t^6 = 0,$$

$$\text{i.e. } t^6 - 21t^4 + 35t^2 - 7 = 0.$$

It will be observed that this equation is a cubic for t^2 and that the roots of this cubic are the three different values of $\tan^2 \theta$ (other than zero) for which $\tan 7\theta$ vanishes. Now $\tan \theta$ vanishes only when θ is zero or a multiple of π : so that the roots of the cubic must be of the form $\tan^2(n\pi/7)$, where n is neither zero nor a multiple of 7. The roots of the cubic are thus $\tan^2(\pi/7)$, $\tan^2(2\pi/7)$, and $\tan^2(3\pi/7)$. It is easily verified that the insertion of any other possible value of n will give one of these values, e.g. $\tan^2(4\pi/7) = \tan^2(3\pi/7)$.

If we write $\alpha_1, \alpha_2, \alpha_3$ for these roots, we have from the properties of equations proved on p. 21,

$$\alpha_1\alpha_2\alpha_3 = 7 \text{ and } \alpha_2\alpha_3 + \alpha_3\alpha_1 + \alpha_1\alpha_2 = 35,$$

$$\text{whence } (1/\alpha_1) + (1/\alpha_2) + (1/\alpha_3) = 5,$$

$$\text{i.e. } \cot^2(\pi/7) + \cot^2(2\pi/7) + \cot^2(3\pi/7) = 5.$$

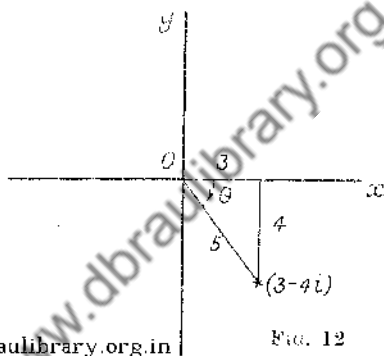

FIG. 12

EXAMPLE 5. Find all the values of z which satisfy the equation $(z + 1)^5 + z^5 = 0$ and show that their representative points lie on a straight line parallel to the imaginary axis.

(U.L.)

Writing the equation in the form $[-(z + 1)/z]^5 = 1$ we see that $-(z + 1)/z$ is a fifth root of unity and so the roots of the equation are given by

$$-(z + 1)/z = 1 \text{ or } \cos k\theta + i \sin k\theta,$$

where $\theta = 2\pi/5$ and k takes in turn the values 1, 2, 3, 4. The real value gives $z = -\frac{1}{2}$ and the complex values give

$$\begin{aligned} z &= -1/(1 + \cos k\theta + i \sin k\theta) \\ &= -1/(2 \cos^2 \frac{1}{2}k\theta + 2i \sin \frac{1}{2}k\theta \cos \frac{1}{2}k\theta) \\ &= -1/[2 \cos \frac{1}{2}k\theta (\cos \frac{1}{2}k\theta + i \sin \frac{1}{2}k\theta)] \\ &= -(\cos \frac{1}{2}k\theta - i \sin \frac{1}{2}k\theta)/(2 \cos \frac{1}{2}k\theta) \\ &= -\frac{1}{2} + \frac{1}{2}i \tan \frac{1}{2}k\theta. \end{aligned}$$

All the roots have the same real part and their representative points lie on the line $x = -\frac{1}{2}$, which is parallel to the imaginary axis.

EXERCISES

- Plot on the Argand diagram the roots of the equation $x^3 + 1 = 0$.
- Calculate, using tables, all the values of $(1 - i)^{1/3}$.
- Find the fifth roots of -1 in the form $a + ib$, giving a and b to four decimals.

Denoting any one of the complex roots by z , find all the values of $(z - z^3)/(1 + z^9)$.

(U.L.)

- Find all the values of $(3 + 4i)^{1/4}$ and represent them on an Argand diagram. Hence solve the simultaneous equations

$$x^4 - 6x^2y^2 + y^4 = 3, \quad xy(x^2 - y^2) = 1.$$

for real values of x and y .

(U.L.)

- Prove that the points which represent $m\omega + n\omega^2$, where ω is a complex cube root of unity and m and n have any zero or positive or negative integral values, are the points of a network of equilateral triangles.

- Prove that every root of the equation

$$(1 + x)^5 + x^5 = 0$$

has $-\frac{1}{2}$ for its real part.

- Prove that $(1 + \sin \phi + i \cos \phi)^n (1 + \sin \phi - i \cos \phi)^{-n}$

$$= \cos n(\frac{1}{2}\pi - \phi) + i \sin n(\frac{1}{2}\pi - \phi). \quad (U.L.)$$

- Solve $x^2 - 2ax \cos \theta + a^2 = 0$ and show that, if x is either root of this equation, $x^{2n} - 2a^n x^n \cos \theta + a^{2n} = 0$, where n is a positive integer.

(U.L.)

9. Solve completely $x^6 + 4x^3 + 8 = 0$ and $x^6 - x^3 + 1 = 0$.

10. If $x_n + iy_n = (1 + i\sqrt{3})^n$, show that

$$x_{n-1}y_n - x_ny_{n-1} = 4^{n-1}\sqrt{3},$$

where n is a positive integer.

(U.L.)

11. If ω is a complex fifth root of unity, find the equation whose roots are the different values of $(1 + \omega)^2$.

12. Expand $\cos n\theta$ in a series of powers of $\cos \theta$, when n is even. Prove that, when n is even,

$$\sum_{r=1}^{n/2} \tan^2[(2r-1)\pi/2n] = \frac{1}{2}n(n-1).$$

13. Find all the values of θ between $-\pi$ and $+\pi$ for which $\sin 3\theta = \sin 4\theta$. Deduce that $\cos(\pi/7)$ is a root of the equation

$$8x^3 - 4x^2 - 4x + 1 = 0.$$

14. If α is a complex root of $z^{13} = 1$, prove that

$$\alpha + \alpha^5 + \alpha^8 + \alpha^{12}$$

is a root of $z^3 + z^2 - 4z + 1 = 0$.

15. If $f(z) = z^3 + 3pz + q$, show that the condition that $f(z)$ and $f'(z)$ should have a common factor is that $4p^3 + q^2 = 0$.

Deduce the condition that the equation $ax^3 + 3bx^2 + 3cx + d = 0$ should have two equal roots.

16. Show that $[1 + \cos(2n+1)\theta]/[1 + \cos \theta]$ is the square of a polynomial of degree n in $\cos \theta$, and find this polynomial when $n = 3$.

(U.L.)

17. Find all the solutions of the equation $(1+x)^4 + x^4 = 0$. (U.L.)

18. Find an expression for $\cos n\theta$ in terms of $\cot \theta$.

Prove that

$$\prod_{m=0}^{n-1} \left[a + b \cot \left(\theta + \frac{m\pi}{n} \right) \right] = r^n \sin(n\theta + n\alpha) \operatorname{cosec} n\theta,$$

where $a = r \cos \alpha$, $b = r \sin \alpha$.

(U.L.)

CHAPTER III

INFINITE SERIES—THE EXPONENTIAL, LOGARITHMIC, CIRCULAR AND HYPERBOLIC FUNCTIONS

Absolute Convergence of Series of Complex Terms. We shall now discuss briefly certain infinite series of complex terms assuming that the reader is already acquainted with the elements of the theory of real series. Consider the infinite series

$$z_1 + z_2 + z_3 + \dots + z_n + \dots$$

in which the terms are complex; so that $z_n = x_n + iy_n$. This series is said to be convergent if the two real series

$$x_1 + x_2 + x_3 + \dots + x_n + \dots$$

and
$$y_1 + y_2 + y_3 + \dots + y_n + \dots$$

are convergent.

Denote by Z_n, X_n, Y_n , respectively, the sums of the first n terms of these three series; then $Z_n = X_n + iY_n$. If the two real series converge to the sums X, Y , respectively, then, as n tends to infinity, Z_n tends to the limit $X + iY$, and this is called *the sum to infinity of the complex series*.

The infinite series of positive real terms

$$|z_1| + |z_2| + |z_3| + \dots + |z_n| + \dots$$

is defined as the *series of moduli*.

It will now be shown that, if the series of moduli is convergent, the complex series is convergent also. Since x_n and y_n are real, $|x_n| \leq (x_n^2 + y_n^2)^{1/2}$ and $|y_n| \leq (x_n^2 + y_n^2)^{1/2}$.

Thus, if the series $\sum_{n=1}^{\infty} |z_n|$ converges, the series $\sum_{n=1}^{\infty} |x_n|$ and $\sum_{n=1}^{\infty} |y_n|$ must also converge, for the n th term of either of the last two series cannot exceed the corresponding term in the series of moduli. The real series $\sum_{n=1}^{\infty} x_n$ and $\sum_{n=1}^{\infty} y_n$ are therefore absolutely convergent and the series $\sum_{n=1}^{\infty} z_n$ has a finite sum to infinity. When the series of moduli converges, the series of complex terms is said to be *absolutely convergent*.

EXAMPLE 1. Consider the series

$$z - z^2/2 + z^3/3 - z^4/4 + \dots + (-1)^{n-1}(z^n/n) + \dots$$

The series of moduli is

$$r + r^2/2 + r^3/3 + r^4/4 + \dots + (r^n/n) + \dots,$$

where $r = |z|$.

Apply to this d'Alembert's ratio test for convergence. The ratio of the n th to the $(n-1)$ th term is $(1 - 1/n)r$ and this tends to the limit r when n tends to infinity. The series converges therefore when $r < 1$ and so the original series is absolutely convergent when $|z| < 1$.

A series of the form

$$a_0 + a_1z + a_2z^2 + a_3z^3 + \dots + a_nz^n + \dots,$$

in which the coefficients a are independent of z , is called a *power series* in z . A particular case is the series in the above example.

The Exponential Series. Consider the series

$$1 + (z/1!) + (z^2/2!) + (z^3/3!) + \dots + (z^n/n!) + \dots,$$

where $z = r(\cos \theta + i \sin \theta)$.

The series of moduli is

$$1 + (r/1!) + (r^2/2!) + (r^3/3!) + \dots + (r^n/n!) + \dots,$$

which is convergent for all finite values of r , since the ratio of the n th to the preceding term is equal to r/n and this tends to zero as n tends to infinity. The original series converges therefore for all finite values of z .

It is a well-known result that, when z is real, the sum of the series is e^z , where e is the base of natural logarithms and is defined by the equation

$$e = 1 + (1/1!) + (1/2!) + (1/3!) + \dots + (1/n!) + \dots$$

We define e^z , when z is complex, to be the sum to infinity of the above series, viz.

$$e^z = 1 + (z/1!) + (z^2/2!) + (z^3/3!) + \dots = \sum_{n=0}^{\infty} (z^n/n!).$$

By multiplying the two series together we may show that

$$e^z \times e^{z'} = \sum_{n=0}^{\infty} [(z + z')^n/n!].$$

From the definition above it follows that the sum of the series on the right-hand side is $e^{(z+z')}$; whence it is seen that the index-law for multiplication, used for real indices, still holds good when the indices are complex,

$$\text{i.e.} \quad e^z \times e^{z'} = e^{(z+z')}$$

for all values of z and z' . In particular,

$$e^{x+iy} = e^x \times e^{iy}.$$

In order to facilitate printing, $\exp(z)$ is often used in place of e^z : this notation is especially useful when z is replaced by a more complicated function.

The Exponential Values of Circular Functions. Taking $z = i\theta$, where θ is real, we have

$$\begin{aligned} e^{i\theta} &= \sum_{n=0}^{\infty} (i^n \theta^n / n!) \\ &= (1 - \theta^2/2! + \theta^4/4! - \theta^6/6! + \dots) \\ &\quad + i(\theta - \theta^3/3! + \theta^5/5! - \theta^7/7! + \dots). \end{aligned}$$

The real and imaginary parts of the series are the well-known expansions, by Maclaurin's theorem, of the cosine and sine functions of θ , and so we have

$$e^{i\theta} = \cos \theta + i \sin \theta.$$

If the sign of θ be changed, we have

$$e^{-i\theta} = \cos \theta - i \sin \theta,$$

and addition and subtraction of these two results give

$$\cos \theta = (e^{i\theta} + e^{-i\theta})/2, \quad \sin \theta = (e^{i\theta} - e^{-i\theta})/2i.$$

It will be noted that the last two equations are merely re-statements of the series for $\cos \theta$ and $\sin \theta$; for $e^{i\theta}$ and $e^{-i\theta}$ are by definition the sums of certain series. It is often convenient, for the sake of brevity, to make use of the result obtained above and write the expression $r(\cos \theta + i \sin \theta)$ in the form $re^{i\theta}$ or $r \exp(i\theta)$.

The n th roots of this number can be compactly expressed as $r^{1/n} \exp[i(\theta + 2k\pi)/n]$, where $k = 0, 1, 2, 3, \dots, (n-1)$.

Stated in the exponential form, de Moivre's theorem (p. 23) becomes $(e^{i\theta})^n = e^{in\theta}$, which is the extension to imaginary indices of a well-known index-law.

EXAMPLE 2. Show that

$$[(1 + it)/(1 - it)] + [(1 - it)/(1 + it)] = 2 \cos \theta,$$

where $t = \tan \frac{1}{2}\theta$.

$$\begin{aligned} \text{Since } (1 + it)/(1 - it) &= (\cos \frac{1}{2}\theta + i \sin \frac{1}{2}\theta)/(\cos \frac{1}{2}\theta - i \sin \frac{1}{2}\theta) \\ &= \exp(\frac{1}{2}i\theta)/\exp(-\frac{1}{2}i\theta) \\ &= \exp(i\theta), \end{aligned}$$

the expression on the left-hand side reduces to

$$\exp(i\theta) + \exp(-i\theta),$$

which is $2 \cos \theta$.

EXAMPLE 3. Show that

$$32 \cos^4 \theta \sin^2 \theta = 2 + \cos 2\theta - 2 \cos 4\theta - \cos 6\theta.$$

Inserting the exponential values of $\cos \theta$ and $\sin \theta$, and writing z for $\exp(i\theta)$, we have

$$\begin{aligned} 32 \cos^4 \theta \sin^2 \theta &= -\frac{1}{2}(z + z^{-1})^4(z - z^{-1})^2 \\ &= -\frac{1}{2}(z^2 - z^{-2})^2(z + z^{-1})^2 \\ &= -\frac{1}{2}(z^4 - 2 + z^{-4})(z^2 + 2 + z^{-2}) \\ &= -\frac{1}{2}(z^6 + z^{-6} + 2z^4 + 2z^{-4} - z^2 - z^{-2} - 4) \\ &= -\cos 6\theta - 2 \cos 4\theta + \cos 2\theta + 2. \end{aligned}$$

THE FACTORS OF $z^{2n} - 1$ have been shown on p. 22 that a polynomial with real coefficients can be resolved into linear and quadratic factors in which the coefficients are real: we shall obtain these factors for the above expression, n being a positive integer.

The roots of the equation $z^{2n} = 1$ are the values of $\exp(ik\pi/n)$, where $k = 0, 1, 2, \dots, 2n - 1$ (see p. 24). The roots given by $k = 0$ and $k = n$ are real, viz. 1 and -1 , and the others may be arranged in the conjugate pairs:

$$\exp(is\pi/n) \text{ and } \exp[i(2n - s)\pi/n] = \exp(-is\pi/n)$$

where $s = 1, 2, 3, \dots, n - 1$.

The conjugate pairs of complex roots give the factors

$$[z - \exp(is\pi/n)][z - \exp(-is\pi/n)] = z^2 - 2z \cos(s\pi/n) + 1$$

and we may write

$$z^{2n} - 1 = (z^2 - 1) \prod_{s=1}^{n-1} [z^2 - 2z \cos(s\pi/n) + 1].$$

THE FACTORS OF $z^{2n+1} - 1$. This function vanishes when $z = 1$ and when $z = \exp [2ik\pi/(2n + 1)]$, where $k = 1, 2, 3, \dots, 2n$. The $2n$ complex roots may be arranged in the conjugate pairs:

$$\begin{aligned} \exp [2is\pi/(2n + 1)] \text{ and } \exp [2i(2n + 1 - s)\pi/(2n + 1)] \\ = \exp [-2is\pi/(2n + 1)], \end{aligned}$$

where $s = 1, 2, 3, \dots, n$.

Hence

$$\begin{aligned} z^{2n+1} - 1 &= (z - 1) \prod_{s=1}^n \{z - \exp [2is\pi/(2n + 1)]\} \\ &\quad \{z - \exp [-2is\pi/(2n + 1)]\} \\ &= (z - 1) \prod_{s=1}^n \{z^2 - 2z \cos [2s\pi/(2n + 1)] + 1\}. \end{aligned}$$

Application to the Summation of Series. Certain trigonometric series may be summed by making use of the fact that $\exp(i\theta) = \cos \theta + i \sin \theta$.

EXAMPLE 4. If

$$C = 1 + r \cos \theta + r^2 \cos 2\theta + \dots + r^{n-1} \cos (n-1)\theta$$

$$\text{and } S = r \sin \theta + r^2 \sin 2\theta + \dots + r^{n-1} \sin (n-1)\theta,$$

$$\text{then } C + iS = 1 + z + z^2 + \dots + z^{n-1},$$

$$\text{where } z = r \exp(i\theta),$$

$$\text{i.e. } C + iS = (1 - z^n)/(1 - z)$$

$$= [1 - r^n \exp(in\theta)]/[1 - r \exp(i\theta)]$$

$$= [1 - r^n \exp(in\theta)][1 - r \exp(-i\theta)]/$$

$$[1 - r \exp(i\theta)][1 - r \exp(-i\theta)]$$

$$= \frac{1 - r \exp(-i\theta) - r^n \exp(in\theta) + r^{n+1} \exp[i(n-1)\theta]}{1 - r[\exp(i\theta) + \exp(-i\theta)] + r^2}.$$

The denominator of the fraction is real, being in fact $1 - 2r \cos \theta + r^2$. Expressing the exponentials in the numerator in terms of sines and cosines and equating real and imaginary parts, we have

$$C = \frac{[1 - r \cos \theta - r^n \cos n\theta + r^{n+1} \cos (n-1)\theta]}{[1 - 2r \cos \theta + r^2]},$$

$$\text{and } S = \frac{[r \sin \theta - r^n \sin n\theta + r^{n+1} \sin (n-1)\theta]}{[1 - 2r \cos \theta + r^2]}.$$

EXAMPLE 5. Consider the sum to infinity of the series

$$1 + r \cos \theta + (r^2 \cos 2\theta)/2! + (r^3 \cos 3\theta)/3! + \dots \\ + (r^n \cos n\theta)/n! + \dots$$

Denote the sum of this series by C and let S stand for the sum of the corresponding infinite series

$$r \sin \theta + (r^2 \sin 2\theta)/2! + (r^3 \sin 3\theta)/3! + \dots \\ + (r^n \sin n\theta)/n! + \dots$$

$$\text{Then } C + iS = 1 + z + z^2/2! + z^3/3! + \dots \\ + z^n/n! + \dots$$

$$= \exp(z),$$

where z has the same meaning as in Example 1.

$$\text{Hence } C + iS = \exp(r \cos \theta + ir \sin \theta) \\ = \exp(r \cos \theta) \cdot \exp(ir \sin \theta) \\ = \exp(r \cos \theta) \cdot [\cos(r \sin \theta) + i \sin(r \sin \theta)],$$

and therefore $C = \exp(r \cos \theta) \cdot \cos(r \sin \theta)$

$$S = \exp(r \cos \theta) \cdot \sin(r \sin \theta).$$

The series which are denoted by C and S in the second example are, of course, convergent for all finite values of r since they are the real and imaginary parts of the series $\exp(z)$ which converges for all finite values of z .

Logarithms of a Complex Number. If z is any complex number and w satisfies the equation $z = \exp(w)$, then w is defined as a *logarithm of z to the base e* . As will be shown below, an infinite number of values of w can be found when z is given and so every number has an infinite number of logarithms.

Let z be expressed in the form $r(\cos \theta + i \sin \theta)$, where r is the modulus and θ the principal argument of z . Then, if $w = u + iv$, we have

$$r(\cos \theta + i \sin \theta) = \exp(u + iv) \\ = \exp(u) \cdot \exp(iv) \\ = \exp(u) \cdot (\cos v + i \sin v),$$

whence $\exp(u) = r$ and $v = \theta + 2n\pi$,

where $n = 0, \pm 1, \pm 2, \pm 3, \dots$

Since u is real it is the ordinary real natural logarithm of the positive number r which we denote by $\log_e r$, and it is unique;

but v can take an infinite number of values differing by multiples of 2π . The logarithms of z are then given by

$$\log_e z = \log_e r + i(\theta + 2n\pi),$$

where n is zero or any integer. The value given by taking $n = 0$ is defined as the *principal logarithm* of z ; its imaginary part is the *principal argument* of z .

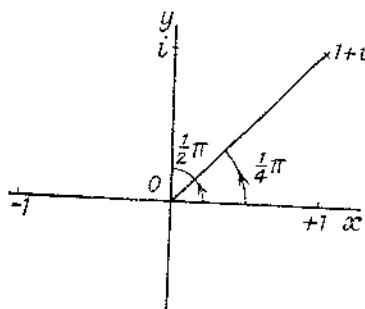

FIG. 13

When finding the logarithms of a given complex number, it is advisable to make use of the Argand diagram in order to determine the principal argument of the number. For instance, if the values of the logarithm of 2 are required, we note that $r = 2$ and $\theta = 0$ and so the general value is

$$(\log_e 2 + 2ni\pi)$$

with $n = 0, \pm 1, \pm 2, \pm 3, \dots$

Again, -1 has modulus 1 and principal argument $\pm \pi$ (there is an ambiguity here to which reference was made on p. 6). The general value of $\log_e (-1)$ is therefore $(2n + 1)i\pi$. Similarly, the general logarithm of $(1 + i)$ is

$$\left[\frac{1}{2} \log_e 2 + (2n + \frac{1}{4})i\pi \right]$$

(Fig. 13) and that of i is $(2n + \frac{1}{2})i\pi$.

Since the logarithm is a many-valued function, it is necessary to take great care in dealing with it, otherwise it is easy to get into difficulties. Consider the following argument—

“It is well known that $\log(1/x) = -\log x$. Putting $x = -1$, we have $\log(-1) = -\log(-1)$, whence $\log(-1) = 0$ and so $-1 = \exp(0) = +1$.”

The fallacy arises from the fact that, in the above argument, the logarithm is treated as a one-valued function.

$$\begin{aligned} \text{Since} \quad \log [x \times (1/x)] &= \log 1 = 2ni\pi, \\ &\log x + \log (1/x) = 2ni\pi \\ \text{and so} \quad \log (-1) + \log (-1) &= 2ni\pi, \end{aligned}$$

where n is zero or an integer.

The last equation simply tells us that the sum of any two values of $\log(-1)$ is zero or an even multiple of $i\pi$. This is true, because the general value of $\log(-1)$ is an odd multiple of $i\pi$ (see p. 36).

In the given argument, the first equation asserts that $\log 1$ is zero, which is only one of an infinite number of possible values: in the deduction from the next equation it is assumed that the value of the logarithm of -1 which is on the left is the same as that on the right. All we are justified in concluding from the statement $\log(-1) = -\log(-1)$ is that *any one* value of the logarithm is equal to minus *some other* value. This is true since the values are $\pm i\pi, \pm 3i\pi, \pm 5i\pi, \dots$; but it is untrue to say that any one value is equal to minus itself.

THE FUNCTION a^z . If a and z are any complex numbers, we define a^z by the equation

$$a^z = \exp(z \log_e a).$$

Since the logarithm has an infinite number of values, this function, in general, also has an infinite number of values.

If $|a| = R$, if the principal argument of a is β and if $z = x + iy$, then

$$\log_e a = \log R + i(\beta + 2n\pi)$$

and, from the definition,

$$\begin{aligned} a^z &= \exp\{(x + iy)[\log R + i(\beta + 2n\pi)]\} \\ &= \exp\{x \log R - y(\beta + 2n\pi) + i[y \log R + x(\beta + 2n\pi)]\}, \end{aligned}$$

where n can take any of the values $0, \pm 1, \pm 2, \pm 3, \dots$

As a particular case consider the values of i^i . Since

$$\begin{aligned} \log i &= (2n + \frac{1}{2})i\pi, \\ i^i &= \exp[-(2n + \frac{1}{2})\pi], \end{aligned}$$

where $n = 0, \pm 1, \pm 2, \pm 3, \dots$

Thus the expression has an infinite number of values all of which are real.

Generalized Circular and Hyperbolic Functions. The circular functions of any complex number z are defined by the relations

$$\begin{aligned} \sin z &= [\exp(iz) - \exp(-iz)]/2i, \\ \cos z &= [\exp(iz) + \exp(-iz)]/2, \\ \tan z &= \sin z/\cos z = 1/\cot z, \end{aligned}$$

$$\operatorname{cosec} z = 1/\sin z,$$

$$\sec z = 1/\cos z,$$

where $\exp(iz)$ is the sum of the power series $\sum_{n=0}^{\infty} (iz)^n/n!$

On comparing the above values of $\sin z$ and $\cos z$ with the exponential values of $\sin \theta$ and $\cos \theta$, where θ is real, given on p. 32, we see at once that the definitions hold good when z is real. We have generalized our trigonometry in such a way as to include as special cases the results of real trigonometry.

From the equations which define the sine and cosine we have

$$\cos z + i \sin z = \exp(iz)$$

$$\text{and} \quad \cos z - i \sin z = \exp(-iz),$$

$$\text{whence } (\cos z + i \sin z)(\cos z - i \sin z) = \exp(iz) \cdot \exp(-iz) \\ = \exp(0),$$

$$\text{i.e.} \quad \cos^2 z + \sin^2 z = 1.$$

If u and v are any two complex numbers,

$$\begin{aligned} \cos u \cos v &= \frac{1}{4}[\exp(iu) + \exp(-iu)][\exp(iv) + \exp(-iv)] \\ &= \frac{1}{4}\{\exp[i(u+v)] + \exp[-i(u+v)] \\ &\quad + \exp[i(u-v)] + \exp[-i(u-v)]\} \\ &= \frac{1}{2}[\cos(u+v) + \cos(u-v)], \end{aligned}$$

and

$$\begin{aligned} \sin u \sin v &= -\frac{1}{4}[\exp(iu) - \exp(-iu)][\exp(iv) - \exp(-iv)] \\ &= -\frac{1}{4}\{\exp[i(u+v)] + \exp[-i(u+v)] \\ &\quad - \exp[i(u-v)] - \exp[-i(u-v)]\} \\ &= \frac{1}{2}[\cos(u-v) - \cos(u+v)]. \end{aligned}$$

Addition and subtraction of these results give

$$\cos(u \pm v) = \cos u \cos v \mp \sin u \sin v,$$

where both upper or both lower signs are to be taken.

In an exactly similar way it can be shown that

$$\sin(u \pm v) = \sin u \cos v \pm \sin v \cos u.$$

By division it follows that

$$\tan(u \pm v) = (\tan u \pm \tan v)/(1 \mp \tan u \tan v).$$

These formulae are exactly the same as if u and v were real: in fact, all the addition formulae of elementary real trigonometry are valid for complex arguments.

In a similar manner we define the generalized hyperbolic functions by the relations

$$\sinh z = \frac{1}{2}[\exp(z) - \exp(-z)],$$

$$\cosh z = \frac{1}{2}[\exp(z) + \exp(-z)],$$

$$\tanh z = \sinh z / \cosh z = 1 / \coth z,$$

$$\operatorname{cosech} z = 1 / \sinh z,$$

$$\operatorname{sech} z = 1 / \cosh z.$$

From these definitions it follows that

$$\begin{aligned} (\cosh z + \sinh z)(\cosh z - \sinh z) &= [\exp z][\exp -z] \\ &= \exp(0) \end{aligned}$$

$$\text{and so} \quad \cosh^2 z - \sinh^2 z = 1.$$

The addition formulae may be obtained in the same way as for the circular functions and are

$$\cosh(u \pm v) = \cosh u \cosh v \pm \sinh u \sinh v,$$

$$\sinh(u \pm v) = \sinh u \cosh v \pm \sinh v \cosh u,$$

$$\tanh(u \pm v) = \frac{(\tanh u \pm \tanh v)}{1 \pm \tanh u \tanh v},$$

both upper or both lower signs being taken in each instance.

If z is purely imaginary and equal to iy , where y is real, we have from the definitions

$$\sin iy = [\exp(-y) - \exp(y)]/2i = i \sinh y,$$

$$\cos iy = [\exp(-y) + \exp(y)]/2 = \cosh y,$$

$$\sinh iy = \frac{1}{2}[\exp(iy) - \exp(-iy)] = i \sin y,$$

$$\cosh iy = \frac{1}{2}[\exp(iy) + \exp(-iy)] = \cos y.$$

Hence we can express the sine, cosine and tangent of $z = x + iy$ in the form $A + iB$. We have

$$\begin{aligned} \sin(x + iy) &= \sin x \cos iy + \cos x \sin iy \\ &= \sin x \cosh y + i \cos x \sinh y \end{aligned}$$

$$\begin{aligned} \cos(x + iy) &= \cos x \cos iy - \sin x \sin iy \\ &= \cos x \cosh y - i \sin x \sinh y. \end{aligned}$$

The corresponding result for the tangent may be obtained by division of these results or, more neatly, thus—

$$\begin{aligned}\tan(x + iy) &= 2 \sin(x + iy) \cos(x - iy) / 2 \cos(x + iy) \cos(x - iy) \\ &= (\sin 2x + \sin 2iy) / (\cos 2x + \cos 2iy) \\ &= (\sin 2x + i \sinh 2y) / (\cos 2x + \cosh 2y).\end{aligned}$$

It will be noted that all the circular and hyperbolic functions have been defined by means of power series in z having real coefficients. It follows that, if f denotes any one of these functions and $f(x + iy) = P + iQ$, where P and Q are real, then $f(x - iy) = P - iQ$, whence

$$|f(x + iy)|^2 = P^2 + Q^2 = f(x + iy) \cdot f(x - iy).$$

The application of this principle often gives very neatly the modulus of a function of this type. Thus,

$$\begin{aligned}|\sin(x + iy)|^2 &= \sin(x + iy) \cdot \sin(x - iy) \\ &= \frac{1}{2}(\cos 2iy - \cos 2x) \\ &= \frac{1}{2}(\cosh 2y - \cos 2x) \\ &= \cosh^2 y - \cos^2 x.\end{aligned}$$

$$\begin{aligned}\text{Also, } |\cos(x + iy)|^2 &= \cos(x + iy) \cdot \cos(x - iy) \\ &= \frac{1}{2}(\cos 2x + \cos 2iy) \\ &= \frac{1}{2}(\cos 2x + \cosh 2y) \\ &= \cos^2 x + \cosh^2 y\end{aligned}$$

$$\text{and } |\tan(x + iy)|^2 = (\cosh 2y - \cos 2x) / (\cos 2x + \cosh 2y).$$

The corresponding results for the hyperbolic functions may be obtained in a similar way, and are left as an exercise for the reader.

EXAMPLE 6. If $\cos(a + ib) \cdot \cosh(x + iy) = 1$, where a, b, x, y are all real, prove that, in general,

$$\tan a \tanh b = \tanh x \tan y. \quad (U.L.)$$

Expanding each of the factors on the left-hand side of the given relation, we have

$$(\cos a \cosh b - i \sin a \sinh b) (\cosh x \cos y + i \sinh x \sin y) = 1.$$

The imaginary part of the product vanishes and so

$$\cos a \cosh b \cosh x \cos y (\tanh x \tan y - \tan a \tanh b) = 0.$$

$$\text{Hence } \tanh x \tan y = \tan a \tanh b,$$

unless $\cos a$ or $\cos y$ vanishes: neither of the factors $\cosh b$, $\cosh x$ can vanish since the least value that either can have is unity.

EXAMPLE 7. If $\tanh(u + iv) = x + iy$, where u, v, x, y are real, find x and y in terms of u and v . Find the values of u and v when $x = y = 1$.

(U.L.)

Since

$$x + iy = \tanh(u + iv), \quad x - iy = \tanh(u - iv)$$

$$\text{and } x = \frac{1}{2} \tanh(u + iv) + \frac{1}{2} \tanh(u - iv)$$

$$= \frac{\sinh(u + iv) \cosh(u - iv) + \cosh(u + iv) \sinh(u - iv)}{2 \cosh(u + iv) \cosh(u - iv)}$$

$$= \sinh(u + iv + u - iv) / (\cosh 2u + \cosh 2iv)$$

$$= \sinh 2u / (\cosh 2u + \cos 2v).$$

Similarly,

$$iy = \frac{1}{2} \tanh(u + iv) - \frac{1}{2} \tanh(u - iv)$$

$$= \sinh 2iv / (\cosh 2u + \cosh 2iv),$$

which gives

$$y = \sin 2v / (\cosh 2u + \cos 2v).$$

When $x = y = 1$, we have

$$\sin 2v > 0,$$

$$\tanh(u + iv) = 1 + i, \text{ and } \tanh(u - iv) = 1 - i.$$

Therefore $\tanh 2u = \tanh(u + iv + u - iv)$

$$= [(1 + i) + (1 - i)] / [1 + (1 + i)(1 - i)]$$

$$= \frac{2}{3}.$$

Also $\tanh 2iv = \tanh(u + iv - u + iv)$

$$= [(1 + i) - (1 - i)] / [1 - (1 + i)(1 - i)]$$

$$= -2i,$$

i.e. $\tan 2v = -2,$

whence $2v$ is in the second quadrant and

$$v = \frac{1}{2}(n\pi - \tan^{-1} 2),$$

where

$$n = \pm 1, \pm 3, \pm 5, \dots$$

Since $\tanh 2u = 2/3$, u and $\sinh 2u$ must be positive. From the identity $\operatorname{sech}^2 2u = 1 - \tanh^2 2u$, we deduce that

$$\cosh 2u = 3/\sqrt{5} \text{ and } \sinh 2u = 2/\sqrt{5}.$$

As $\exp(2u) = \sinh 2u + \cosh 2u = \sqrt{5}$, it follows that

$$u = \frac{1}{4} \log_5 5.$$

EXAMPLE 8. If $\log[\cot(x + iy)] = u - iv$, prove that

$$\coth u = \cosh 2y \sec 2x \text{ and } \cot v = \sin 2x \operatorname{cosech} 2y.$$

Show that, if x lies between $-\frac{1}{2}\pi$ and $\frac{1}{2}\pi$, v lies in the same quadrant as $\arg(x + iy)$.

From the data,

$$\exp(u - iv) = \cot(x + iy) \text{ and}$$

$$\exp(u + iv) = \cot(x - iy),$$

therefore

$$\begin{aligned} \exp(2u) &= \exp(u + iv) \exp(u - iv) \\ &= \cos(x + iy) \cos(x - iy) / \sin(x + iy) \sin(x - iy) \\ &= (\cos 2x + \cosh 2y) / (\cosh 2y - \cos 2x). \end{aligned}$$

Hence

$$\begin{aligned} \coth u &= [\exp(2u) + 1] / [\exp(2u) - 1] \\ &= \cosh 2y / \cos 2x \\ &= \cosh 2y \sec 2x. \end{aligned}$$

Again

$$\begin{aligned} \exp(2iv) &= \exp(u + iv) / \exp(u - iv) \\ &= \frac{\cos(x + iy) \sin(x - iy)}{\sin(x + iy) \cos(x - iy)} \\ &= (\sin 2x + i \sinh 2y) / (\sin 2x - i \sinh 2y) \end{aligned}$$

$$\begin{aligned} \text{and } \cot 2v &= i[\exp(2iv) + 1] / [\exp(2iv) - 1] \\ &= 2i \sin 2x / (2i \sinh 2y) \\ &= \sin 2x \operatorname{cosech} 2y. \end{aligned}$$

We now have to show that, if x is a positive or negative acute angle, the angles v and $\arg(x + iy)$ are in the same quadrant.

Now $\exp(u - iv)$

$$= \cos(x + iy) \sin(x - iy) / \sin(x + iy) \sin(x - iy),$$

whence $\exp(u) (\cos v - i \sin v)$

$$= (\sin 2x - i \sinh 2y) / (\cosh 2y - \cos 2x),$$

and, equating real and imaginary parts, we have

$$\exp(u) \cos v = \sin 2x / (\cosh 2y - \cos 2x)$$

and $\exp(u) \sin v = \sinh 2y / (\cosh 2y - \cos 2x).$

Now $\exp(u)$ is positive, since u is real, and $(\cosh 2y - \cos 2x)$ is positive, since $\cosh 2y$ cannot be less than 1 and $\cos 2x$ cannot exceed 1. Consequently, $\cos v$ has the same sign as $\sin 2x$, and $\sin v$ has the same sign as $\sinh 2y$. There are four cases to be considered.

Case i. If $\arg(x + iy)$ lies in the first quadrant, both x and y are positive; $\sin 2x$ is positive because $2x$ lies between 0 and π ; and $\sinh 2y$ is positive. Therefore $\sin v$ and $\cos v$ are both positive, and the angle v is in the first quadrant.

Case ii. If $\arg(x + iy)$ is in the second quadrant, then $2x$ lies between 0 and $-\pi$ and $\sin 2x$ is negative, while y is positive. The angle v then has a negative cosine, a positive sine, and therefore lies in the second quadrant.

Case iii. When $\arg(x + iy)$ is in the third quadrant, $2x$ lies between 0 and $-\pi$ and $\sin 2x$ is negative, while y and therefore $\sinh 2y$ are negative. Since $\sin v$ and $\cos v$ are now both negative, v is in the third quadrant.

Case iv. If $\arg(x + iy)$ is in the fourth quadrant then $2x$ lies between 0 and π , $\sin 2x$ being positive, while $\sinh 2y$ is negative. Therefore $\cos v$ is positive and $\sin v$ negative; thus v is in the fourth quadrant.

EXAMPLE 9. Prove that the most general value of $\sin^{-1} 4$ is $(2m + \frac{1}{2})\pi \pm i \log(4 + \sqrt{15})$, where m is an integer or zero. (U.L.)

If $\sin z = 4$, $\cos z = \pm i\sqrt{15}$ and $\exp(iz) = \cos z + i \sin z = (4 \pm \sqrt{15})i$, from which we have

$$\begin{aligned} iz &= \log[(4 \pm \sqrt{15})i] \\ &= \log(4 \pm \sqrt{15}) + \log i \\ &= \log(4 \pm \sqrt{15}) + (2m + \frac{1}{2})\pi i, \end{aligned}$$

because the general value of $\log i$ is the principal value plus an even multiple of πi .

$$\begin{aligned} \text{Since } (4 + \sqrt{15})(4 - \sqrt{15}) &= 1, \\ \log(4 + \sqrt{15}) &= -\log(4 - \sqrt{15}), \end{aligned}$$

and we may write the result in the form

$$z = (2m + \frac{1}{2})\pi \pm i \log(4 + \sqrt{15}).$$

EXAMPLE 10. Resolve $x^{2n} + 2x^n \cos n\theta + 1$ into real quadratic factors, n being a positive integer.

Hence show that

$$\cosh n\phi + \cos n\theta = 2^{n-1} \prod_{r=0}^{n-1} \{ \cosh \phi - \cos [\theta + (2r+1)\pi/n] \} \quad (U.L.)$$

The given expression may be factorized in the form

$$[x^n + \exp(in\theta)] [x^n + \exp(-in\theta)]$$

and therefore the zeros of the expression are the roots of the equations

$$x^n = -\exp(in\theta) = \exp i(n\theta + \pi)$$

and

$$x^n = -\exp(-in\theta) = \exp i(-n\theta - \pi)$$

These roots may be obtained by giving r the values 0, 1, 2, 3, ... in $\exp i[\theta + (2r+1)\pi/n]$ and $\exp i[-\theta - (2r+1)\pi/n]$.

The product of the two linear factors which correspond to a given r is

$$\begin{aligned} & \{x - \exp i[\theta + (2r+1)\pi/n]\} \{x - \exp i[-\theta - (2r+1)\pi/n]\} \\ & = x^2 - 2x \cos [\theta + (2r+1)\pi/n] + 1. \end{aligned}$$

Hence $x^{2n} + 2x^n \cos n\theta + 1$

$$= \prod_{r=0}^{n-1} \{x^2 - 2x \cos [\theta + (2r+1)\pi/n] + 1\}.$$

Divide by x^{2n} , put $x = \exp(\phi)$ and it follows that

$$\cosh n\phi + \cos n\theta = 2^{n-1} \prod_{r=0}^{n-1} \{ \cosh \phi - \cos [\theta + (2r+1)\pi/n] \}.$$

EXERCISES

- Express the following numbers in the form $r(\cos \theta + i \sin \theta)$:—
 - $(1 + i\sqrt{3})/(3 - i3)$ and
 - $[\exp(a + ib)]/[\tan \theta + i]$.
- Show that, by a proper choice of A and B , $Ae^{2i\theta} + Be^{-2i\theta}$ can be made equal to $5 \cos 2\theta - 7 \sin 2\theta$.
- Prove by de Moivre's theorem or otherwise that

$$\cos^8 \theta + \sin^8 \theta = (1/64) (\cos 8\theta + 28 \cos 4\theta + 35). \quad (U.L.)$$

4. Express $\sin^6 x \cos x$ in terms of sines of multiples of x .

5. Find the real quadratic factors of $x^8 - 4x^4 + 16$.

6. Obtain the three real quadratic factors of $x^6 + 8x^3 + 64$.

7. Show that $\sin n\theta = 2^{n-1} \sin \theta \prod_{r=1}^{n-1} [\cos \theta - \cos (r\pi/n)]$ and that

$$n \sin \theta - \operatorname{cosec} n\theta = \sum_{r=1}^{n-1} A_r / [\cos \theta - \cos (r\pi/n)],$$

where $A_r = (-1)^{r-1} \cdot \sin^2 (r\pi/n)$. (U.L.)

8. Show that

$$\sin (2n+1)\theta = (2n+1) \sin \theta \prod_{r=1}^n [1 - \sin^2 \theta \operatorname{cosec}^2 (r\pi/(2n+1))].$$

(U.L.)

9. Show that the roots of the equation $(x^2 - a^2)^n = (2ax)^n$ are

$$a \{ e^{2r\pi i/n} \pm e^{r\pi i/n} \sqrt{2 \cos (2r\pi/n)} \},$$

where $r = 0, 1, 2, \dots, n-1$. (U.L.)

10. If a, b, c are real and $a^2 + b^2 > c^2$, prove that

$$\prod_{s=0}^{n-1} [a \cos (2s\pi/n) + b \sin (2s\pi/n) - c] = (-\frac{1}{2})^{n-1} r^n (\cos n\phi - \cos n\theta),$$

where $r = +\sqrt{a^2 + b^2}$, $r \cos \phi = a$, $r \sin \phi = b$, $r \cos \theta = c$.

(U.L.)

11. Show that $\sum_{n=1}^{\infty} nx^{n-1} \cos (n-1)\theta$

$$= \frac{(1 - x \cos \theta)^2 - x^2 \sin^2 \theta}{(1 - 2x \cos \theta + x^2)^2},$$

when $|x| < 1$.

12. If $a = \cos A + i \sin A$, $b = \cos B + i \sin B$, $c = \cos C + i \sin C$, express $\Sigma (\cos 3A + i \sin 3A) \sin (B - C)$ in terms of a, b, c .

Reduce or otherwise prove that

$$\begin{aligned} \Sigma \cos 3A \sin (B - C) &= 4 \sin A \sin B \sin C \Pi \sin (B - C) \\ \Sigma \sin 3A \sin (B - C) &= 4 \sin (A + B + C) \Pi \sin (B - C). \end{aligned}$$

(U.L.)

13. If $\cosh (u + iv) = \tan (a + ib)$ prove that

$$\cosh 2u + \cos 2v = 2(\cosh 2b - \cos 2a)/(\cosh 2b + \cos 2a).$$

14. Prove that the logarithms of the ratio of two conjugate numbers are purely imaginary.

15. Give a definition of a^z valid when a and z are any complex numbers.

Are the following statements consistent with your definition?

$$(i) (1+i)^{\sqrt{2}} \cdot (1-i)^{\sqrt{2}} = 2\sqrt{2}; \quad (ii) i^{1+i} \cdot i^{1-i} = -1. \quad (U.L.)$$

16. Find, in terms of the modulus and argument of a , the moduli and arguments of a^{a+iv} .

Show that all the points which represent the values of a^{iy} lie on a straight line through the origin, and that all the points which represent the values of a^x lie on a circle, a being complex and x and y being real.

17. Prove that $\log [\sin (x + iy) \operatorname{cosec} (x - iy)] = 2i \tan^{-1} (\tanh y \cot x)$.

18. If $p = a + ib$ and $q = a - ib$, where a and b are real, show that (i) $pe^p + qe^q$ is real; (ii) $\log (\cos q \sec p)$ is wholly imaginary and has the value $i\theta$ such that $\tan \theta = \sin 2a \sinh 2b / (1 + \cos 2a \cosh 2b)$.

(U.L.)

19. If $x + iy = \cos(u + iv)$, prove that

$$(1 + x)^2 + y^2 = (\cosh v + \cos u)^2$$

and

$$(1 - x)^2 + y^2 = (\cosh v - \cos u)^2.$$

If $x = \cos \theta$ and $y = \sin \theta$ ($0 < \theta < \pi$), find $\cos u$ and $\cosh v$ in terms of $\cos \frac{1}{2}\theta$ and $\sin \frac{1}{2}\theta$, justifying the choice of signs when square roots are taken.

20. If $x + iy = c \cosh(\theta + i\phi)$, prove that

$$x^2 \operatorname{sech}^2 \theta + y^2 \operatorname{cosech}^2 \theta = c^2, \text{ and } x^2 \sec^2 \phi - y^2 \operatorname{cosec}^2 \phi = c^2.$$

21. If $\cos(u + iv) = e^{i\pi/6}$, u and v are real and v is positive, show that $u = (2n - \frac{1}{2})\pi$ and $v = \log_e [2 \cos(\pi/12)]$.

22. If $\sin(1 + i) = r(\cos \theta + i \sin \theta)$, find the numerical values of r and θ .

23. Show that the equation $z + a \cot z = 0$, where a is real and positive, has no complex roots and only two purely imaginary roots, and that the modulus of each of these is greater than a .

24. If $y \sin x = x \sinh y$, show that x and y cannot both be real and non-zero.

Show that the equation $\tan z = kz$, where k is real, can have no complex roots and at most two purely imaginary roots, this occurring when k lies between 0 and 1.

25. Prove that the equation $\cot z = kz$, where k is real, (i) has no roots of the form $a + ib$, where a and b are real and different from zero, and (ii) that, if k is positive, all its roots are real.

26. Prove that every value of either side of the equation

$$2i \cot^{-1} x = \log_e [(x + i)/(x - i)]$$

is equal to a value of the other side.

27. Find the sum of the infinite series $\sin \alpha \sin \beta + \frac{1}{2}x^2 \sin 2\alpha \sin 2\beta + \frac{1}{3}x^3 \sin 3\alpha \sin 3\beta + \dots$, when x, α, β are real and $|x| < 1$.

28. If n is a positive integer, prove that

$$\cos 2n\theta = (-1)^n \prod_{r=1}^n \left[1 - \cos^2 \theta \sec^2 \{(2r - 1)\pi/4n\} \right].$$

29. Obtain the real quadratic factors of $(x^{2n+1} - 1)/(x - 1)$ where n is a positive integer.

Prove that

$$\sinh(2n + 1)\theta \operatorname{cosech} \theta = 2^n \prod_{k=1}^n \left[\cosh 2\theta - \cos \{2k\pi/(2n + 1)\} \right].$$

CHAPTER IV

FUNCTIONS OF A COMPLEX VARIABLE—CONJUGATE EXPRESSIONS—CAUCHY'S THEOREM—CONTOUR INTEGRALS

The Complex Variable. If x and y are variable real numbers, then $z (= x + iy)$ is called a *complex variable*.

The point P , which represents z in the Argand diagram, varies its position as x and y vary: if both x and y vary continuously from x_0, y_0 to x_1, y_1 , respectively, the point P describes a continuous curve in the z -plane from P_0 (the point $x_0 + iy_0$) to P_1 (the point $x_1 + iy_1$).

If both x and y are finite, z is said to be finite: if x and y are not both finite, z is said to be infinite. Clearly the modulus of a finite number is also finite and the number is represented by a point which is at a finite distance from the origin.

Two points P_0, P_1 in the z -plane may be connected by an infinite number of paths which lie in the plane. Consequently, if z varies continuously from z_0 to z_1 , it is necessary to specify the path of variation, i.e. the path along which its representative point travels.

If P_1 coincides with P_0 , the path becomes a closed curve or *contour*. A contour is said to be *simple* if, like a circle or ellipse, it has no multiple point. An example of a contour which is not simple is a figure of eight.

Suppose that a point z (Fig. 14) moves once round a simple contour C which does not surround the origin; then it is clear that $|z|$ and $\arg z$, measured by the angle between the real axis and the vector z , vary continuously and both return to their original values. But if z describes once a simple contour C' which surrounds the origin, $|z|$ varies continuously, and returns to its original value, while $\arg z$ varies continuously and returns to its original value $\pm 2\pi$ according as the point moves round the curve in the trigonometrically positive or negative sense.

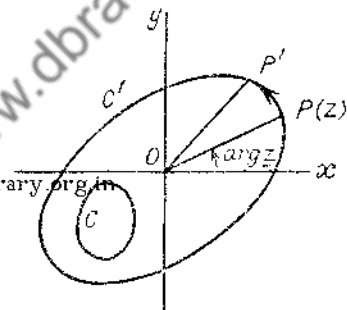

FIG. 14

Let P , which represents z , and P' , which represents $z + \delta z$, be two neighbouring points on any one of the paths which connect P_0 and P_1 . From the vector equation $\overline{PP'} = \overline{OP'} - \overline{OP}$, it follows that the vector $\overline{PP'}$ represents δz and the length of the chord PP' is equal to $|\delta z|$, whence the length of the infinitesimal element of arc is $|\delta z|$ and the angle between the tangent to the path at P and the real axis is $\arg \delta z$.

Functions of a Complex Variable. Suppose that $z (= x + iy)$ and $w (= u + iv)$ are two complex variables which are so related that, to every value of z , there corresponds one and only one value of w . Then we might say that w is a uniform function of z . It will be seen presently that it is advantageous to restrict the definition of a function of a complex variable to a much narrower class of relations.

As particular instances we may take

- (i) $w = z^2$, or $u + iv = x^2 - y^2 + 2ixy$;
- (ii) $w = \exp(z)$, or $u + iv = \exp(x) (\cos y + i \sin y)$;
- (iii) $w = \sin z$, or $u + iv = \sin x \cosh y + i \cos x \sinh y$;
- (iv) $w = |z|$, or $u + iv = \sqrt{(x^2 + y^2)}$;
- (v) $w =$ the conjugate of z , or $u + iv = x - iy$.

It will be observed that, in each case, u and v are themselves real functions of the two real variables x and y : when it is desired to indicate this fact explicitly, we shall write them in the forms $u(x, y)$ and $v(x, y)$.

We shall assume that both u and v are continuous and differentiable with respect to x and y . Consequently, if z is given a small increment $\delta z = \delta x + i\delta y$, the corresponding increment in w is $\delta u + i\delta v$ and is also small.

It is convenient to represent z and w by points in two Argand diagrams which we shall call the z - and w -planes respectively. The point P (Fig. 15) represents z and Q represents the corresponding value of w . On the assumption that u and v are continuous functions of x and y , it follows that, if P describes a continuous curve in the z -plane between two points P_0, P_1 , then Q describes a continuous curve in the w -plane between the corresponding points Q_0, Q_1 .

We shall now consider the relation between a small increment in z and the corresponding increment in w . Suppose first that only the real part of z is varied; so that z (represented by P)

becomes $x + \delta x + iy$ (represented by P_1) and $\delta z = \delta x$. In consequence, w becomes w_1 (represented by Q_1) such that

$$w_1 = u(x + \delta x, y) + iv(x + \delta x, y).$$

The ratio of the increments in w and z is then

$$\frac{(w_1 - w)}{\delta z} = \frac{u(x + \delta x, y) - u(x, y)}{\delta x} + \frac{i[v(x + \delta x, y) - v(x, y)]}{\delta x}$$

and, when δx tends to zero,

$$\text{Limit } (w_1 - w)/\delta z = (\partial u/\partial x) + i(\partial v/\partial x). \quad (1)$$

Now suppose that only the imaginary part of z is varied; so that z becomes $x + iy + i\delta y$, represented by P_2 , and w becomes w_2 , represented by Q_2 .

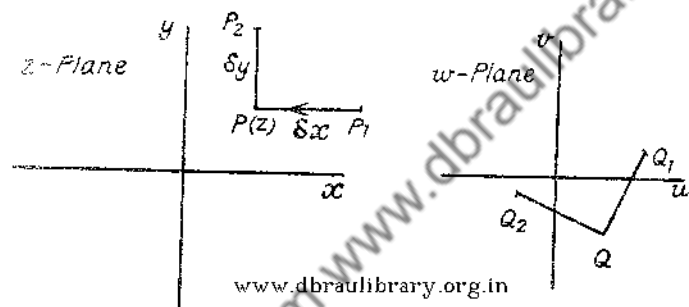

FIG. 15

Then $w_2 = u(x, y + \delta y) + iv(x, y + \delta y)$, $\delta z = i\delta y$ and the ratio of the increments is

$$\frac{(w_2 - w)}{\delta z} = \frac{u(x, y + \delta y) - u(x, y)}{i\delta y} + \frac{v(x, y + \delta y) - v(x, y)}{\delta y}$$

As δy tends to zero,

$$\text{Limit } (w_2 - w)/\delta z = -i(\partial u/\partial y) + (\partial v/\partial y) \quad (2)$$

In general, the limits (1) and (2) are not equal, the ratio $\partial w/\partial z$ does not approach a unique limit as δz tends to zero, and it is not possible to extend the idea of a differential coefficient to perfectly general functions of a complex variable.

It is natural to inquire in what circumstances the two limits are identical. On equating the real and imaginary parts we have as the necessary and sufficient conditions

$$\partial u/\partial x = \partial v/\partial y \quad \text{and} \quad \partial v/\partial x = -\partial u/\partial y \quad (3)$$

We shall now show that, when conditions (3) are satisfied, the ratio $\delta w/\delta z$ approaches a unique limit as δz approaches zero by any path whatever.

Suppose that z is given a general increment and becomes

$$z + \delta z = x + \delta x + iy + i\delta y$$

and that, in consequence, w becomes

$$\begin{aligned} w + \delta w &= u(x + \delta x, y + \delta y) + iv(x + \delta x, y + \delta y) \\ &= u(x, y) + iv(x, y) + u_x\delta x + u_y\delta y + iv_x\delta x + iv_y\delta y, \end{aligned}$$

where we have expanded by Taylor's theorem, retaining only terms of the first order, and where suffixes denote partial derivatives (thus u_x stands for $\partial u/\partial x$).

Hence, as $\delta x \rightarrow 0$ and $\delta y \rightarrow 0$ independently, the limit of $\delta w/\delta z$ is

$$\begin{aligned} & [(u_x + iv_x)\delta x + (u_y + iv_y)\delta y]/(\delta x + i\delta y) \\ &= [(u_x + iv_x)\delta x + (-v_x + iu_x)\delta y]/(\delta x + i\delta y) \\ &= u_x + iv_x \\ &= v_y - iu_y, \text{ using conditions (3).} \end{aligned}$$

Thus when conditions (3) are satisfied, $\delta w/\delta z$ tends to a unique limit as δz tends to zero in any manner: the value of the limit is defined to be the *differential coefficient* or *derivate* of w with respect to z and is denoted by dw/dz . The function w is said to be *monogenic*.

In future, we shall apply the term *function* only to monogenic functions: for those which are not monogenic are of no particular interest in connection with the complex variable and may be adequately treated as a combination of two functions of the real variables x and y .

Consider the functions enumerated on p. 48. In (i) $u = x^2 - y^2$ and $v = 2xy$, whence $u_x = 2x = v_y$ and $u_y = -2y = -v_x$. The function z^2 is therefore monogenic and its derivate is $2z$. Similarly it may be verified that conditions (3) are satisfied by (ii) and (iii). In (iv), $u = \sqrt{x^2 + y^2}$, $v = 0$, and the conditions are not satisfied. Again, in (v) $u = x$, $v = -y$, $u_x = 1$, and $v_y = -1$. It follows that the modulus and the conjugate of z are *not* functions of z in the sense defined above.

Conjugate Functions. If $u + iv = f(x + iy)$, where $f(z)$ is a function of the complex variable z , in the sense specified above,

then u and v are real functions of the two real variables x and y and are called *conjugate functions*.

The partial derivatives of u and v are connected by the relations

$$\frac{\partial u}{\partial x} = \frac{\partial v}{\partial y} \quad \text{and} \quad \frac{\partial u}{\partial y} = -\frac{\partial v}{\partial x},$$

from which we have, by partial differentiation,

$$\frac{\partial^2 v}{\partial x \partial y} = \frac{\partial^2 u}{\partial x^2} = -\frac{\partial^2 u}{\partial y^2} \quad \text{and} \quad \frac{\partial^2 u}{\partial x \partial y} = -\frac{\partial^2 v}{\partial x^2} = \frac{\partial^2 v}{\partial y^2}.$$

It follows that both u and v satisfy the equation

$$\frac{\partial^2 \phi}{\partial x^2} + \frac{\partial^2 \phi}{\partial y^2} = 0 \quad \dots \quad (4)$$

which is Laplace's equation in two dimensions.

This equation occurs constantly in mathematical physics.

By writing down any function of z and separating out its real and imaginary parts, we obtain immediately two solutions of the differential equation. It is obvious then, that the theory of functions of a complex variable must be an invaluable aid towards the solution of two-dimensional problems in mathematical physics.

Construction of a function which has a given real or imaginary part. It is possible to construct a function of z , which, for its real or imaginary part, has a given real function of x and y , only when that given function is a solution of Laplace's equation.

If $f(z)$ is a function of z , we denote by $\bar{f}(z)$ the function obtained from it by replacing every constant which occurs in it by its conjugate number, the variable z being left unaltered. Denoting as usual the conjugate of z by \bar{z} , we see that $\bar{f}(\bar{z})$ is the conjugate of $f(z)$.

$$\begin{aligned} \text{Thus, if } f(z) &= (1+i)z + i = (1+i)(x+iy) + i \\ &= (x-y) + i(x+y+1), \end{aligned}$$

$$\begin{aligned} \text{then } \bar{f}(z) &= (1-i)z - i = (1-i)(x+iy) - i \\ &= (x+y) + i(y-x-1) \end{aligned}$$

$$\begin{aligned} \text{and } \bar{f}(\bar{z}) &= (1-i)\bar{z} - i = (1-i)(x-iy) - i \\ &= (x-y) - i(x+y+1). \end{aligned}$$

In general, let

$$f(z) = u(x, y) + iv(x, y).$$

Then, since

$$x = \frac{1}{2}(z + \bar{z}) \text{ and } y = -\frac{1}{2}i(z - \bar{z}),$$

$$f(z) \equiv u\left[\frac{1}{2}(z + \bar{z}), -\frac{1}{2}i(z - \bar{z})\right] + iv\left[\frac{1}{2}(z + \bar{z}), -\frac{1}{2}i(z - \bar{z})\right]$$

In this identity, \bar{z} may be given any value. Putting $\bar{z} = z$, we have

$$f(z) \equiv u(z, 0) + iv(z, 0) \quad (5)$$

Thus any function of z may be expressed in the form

$$f_1(z) + if_2(z),$$

where $f_1(z)$ and $f_2(z)$ are real when z is real.

If we put $\bar{z} = 0$ in the above identity, we have

$$f(z) \equiv u\left(\frac{1}{2}z, -\frac{1}{2}iz\right) + iv\left(\frac{1}{2}z, -\frac{1}{2}iz\right) \quad (a)$$

Further, if

$$f(z) = u(x, y) + iv(x, y)$$

then

$$\bar{f}(\bar{z}) = u(x, y) - iv(x, y),$$

since u and v are real functions of x and y . Hence

$$u(x, y) = \frac{1}{2}[f(z) + \bar{f}(\bar{z})], \quad v(x, y) = -\frac{1}{2}i[f(z) - \bar{f}(\bar{z})].$$

So

$$\frac{1}{2}[f(z) + \bar{f}(\bar{z})] \equiv u\left(\frac{1}{2}[z + \bar{z}], -\frac{1}{2}i[z - \bar{z}]\right) \quad (b)$$

and

$$-\frac{1}{2}i[f(z) - \bar{f}(\bar{z})] \equiv v\left(\frac{1}{2}[z + \bar{z}], -\frac{1}{2}i[z - \bar{z}]\right) \quad (c)$$

By inserting in either (b) or (c) a convenient value of \bar{z} we may be able to determine $f(z)$ when either u or v is given (as a real function of x and y) which satisfies Laplace's equation.

Putting $\bar{z} = 0$, we have

$$f(z) = 2u\left(\frac{1}{2}z, -\frac{1}{2}iz\right) - f(0) = 2u\left(\frac{1}{2}z, -\frac{1}{2}iz\right) + \text{constant}, \quad (d)$$

$$f(z) = 2iv\left(\frac{1}{2}z, -\frac{1}{2}iz\right) + f(0) = 2iv\left(\frac{1}{2}z, -\frac{1}{2}iz\right) + \text{constant}. \quad (e)$$

If the values of $u\left(\frac{1}{2}z, -\frac{1}{2}iz\right)$ and $v\left(\frac{1}{2}z, -\frac{1}{2}iz\right)$ are determinate, we can use (d) or (e) to determine the function $f(z)$ (but see Example 3 below).

EXAMPLE 1. Take $u = 2xy$, which clearly satisfies equation (4).

From (d), $f(z) = 4\left(\frac{1}{2}z\right)\left(-\frac{1}{2}iz\right) + C = -iz^2 + C$,
where C is a constant.

Here,

$$f(z) = -i(x^2 - y^2 + 2ixy) + C;$$

since $u = 2xy$, C is purely imaginary but otherwise arbitrary.

EXAMPLE 2. The function $v = \exp(x) \cos y$ satisfies Laplace's equation; using (e), we have

$$\begin{aligned} f(z) &= 2i \exp(\frac{1}{2}z) \cos(-\frac{1}{2}iz) + C \\ &= 2i e^{\frac{1}{2}z} \cosh \frac{1}{2}z + C \\ &= i(e^z + 1) + C. \end{aligned}$$

This has v for its imaginary part provided that $i + C$ is real; so $f(z) = i \exp(z) + A$, where A is a real arbitrary constant.

EXAMPLE 3.

If $u - v = [\exp(y) - \cos x + \sin x]/[(\cosh y - \cos x)]$ and $f(\pi/2) = (3 - i)/2$, find $f(z)$.

Now if $u + iv = f(z)$, $iu - v = if(z)$

and $(u - v) + i(u + v) = (1 + i)f(z)$.

Hence $U = u - v$ and $V = u + v$ are conjugate functions, being the real and imaginary parts of $(1 + i)f(z) = F(z)$, say.

Simplifying the given expression for $u - v$, we have

$$U(x, y) = 1 + [(\sinh y + \sin x)/(\cosh y - \cos x)].$$

If we replace x and y by $\frac{1}{2}z$ and $-\frac{1}{2}iz$ respectively, the denominator of the fraction becomes

$$\cosh \frac{1}{2}z - \cos(-\frac{1}{2}iz) = \cosh \frac{1}{2}z - \cosh \frac{1}{2}z = 0;$$

so we cannot use (d).

From (b) $F(z) = 2U(\frac{1}{2}[z + \bar{z}], -\frac{1}{2}i[z - \bar{z}]) - \bar{F}(\bar{z})$.

A convenient value for \bar{z} in this identity is π , and this gives

$$\begin{aligned} F(z) &= 2 - \bar{F}(\pi) + \frac{2[-\sinh \frac{1}{2}i(z - \pi) + \sin \frac{1}{2}(z + \pi)]}{[\cosh \frac{1}{2}i(z - \pi) - \cos \frac{1}{2}(z + \pi)]} \\ &= C + (1 + i) \cot \frac{1}{2}z \end{aligned}$$

It follows that $f(z) = C' + \cot \frac{1}{2}z$.

The constant C' is found by putting $z = \frac{1}{2}\pi$, which gives

$$(3 - i)/2 = C' + 1, \text{ and } C' = (1 - i)/2.$$

The required function is therefore $\cot \frac{1}{2}z + \frac{1}{2}(1 - i)$.

The Curves $u = \text{Constant}$, $v = \text{constant}$. If

$$u + iv = f(x + iy),$$

where $f(z)$ is a uniform function of z , the conjugate functions

are single-valued functions of x and y and therefore, through a given point $z_0 (= x_0 + iy_0)$ in the z -plane will pass one and only one curve of the family $u = \text{constant}$, and one and only one curve of the family $v = \text{constant}$, the equations of these curves being

$$u(x, y) = u(x_0, y_0) \text{ and } v(x, y) = v(x_0, y_0).$$

For example, if $u + iv = (x + iy)^2$, the two curves are the rectangular hyperbolas $x^2 - y^2 = x_0^2 - y_0^2$ and $xy = x_0y_0$.

It is convenient to refer to the two families of curves as the u -system and the v -system.

Suppose that (x, y) and $(x + \delta x, y + \delta y)$ are the co-ordinates of two neighbouring points on the curve $u = \text{constant}$. Then

$$u(x + \delta x, y + \delta y) - u(x, y) = 0$$

and, retaining only terms of the first order we have, on expansion,

$$u_x \delta x + u_y \delta y = 0,$$

whence it follows that the value of dy/dx at the point (x, y) , i.e. the gradient of the curve at the point (x, y) , is equal to $-u_x/u_y$.

In the same way, the gradient of the curve of the v -system through the point (x, y) is v_x/v_y .

The product of the gradients of the two curves at their point of intersection (x, y) is therefore

$$u_x v_x / u_y v_y = -1, \text{ since } u_x = v_y \text{ and } u_y = -v_x.$$

and we have the important result that curves of the u - and v -systems intersect at right angles.

In applications to electrostatics and to the theory of gravitational potential, the two systems of curves are the lines of force and the equipotential lines; in hydrodynamics they are the stream lines and the velocity potential lines.

EXAMPLE 4. If $u + iv = 1/z = (x - iy)/(x^2 + y^2)$, the u -system is given by $x^2 + y^2 = 2kx$ and the v -system by $x^2 + y^2 = 2k'y$, where k, k' are arbitrary. These are circles touching Oy at O and Ox at O , respectively. Each circle of the first family intersects orthogonally every member of the second family.

EXAMPLE 5. If $u + iv = \log z$, then $u = \log r$ and $v = \arg z$.

The curves $u = \text{constant}$ are circles with their centres at the origin, and $v = \text{constant}$ gives the family of straight lines radiating from the origin and cutting the circles orthogonally.

THE CONDITION THAT A GIVEN FAMILY OF CURVES SHOULD BE u - OR v -SYSTEM. The curves given by the equation $u = \text{constant}$ have the characteristic property that u satisfies Laplace's equation in two dimensions. But the equation is not necessarily the simplest form from which the family may be determined: for instance, in Example 5 we have the equation of the circles in the form $\log r = \text{constant}$ instead of in one of the simpler and more usual forms $r = \text{constant}$ and $x^2 + y^2 = \text{constant}$, in which the expressions on the left-hand sides are *not* solutions of Laplace's equation.

Let us consider then in what circumstances a family of curves given by

$$F(x, y) = \text{constant}$$

is expressible in the form

$$u = \text{constant},$$

where u satisfies Laplace's equation.

If such a reduction is possible, it is clear that u must be some function of $F(x, y)$; for, when $F(x, y)$ is constant, u has to be constant.

$$\text{Let } u = \phi(F).$$

$$\text{Then } u_x = \phi'(F) \cdot F_x, \quad u_{xx} = \phi''(F) \cdot F_x^2 + \phi'(F) \cdot F_{xx},$$

$$\text{and } u_y = \phi'(F) \cdot F_y, \quad u_{yy} = \phi''(F) \cdot F_y^2 + \phi'(F) \cdot F_{yy}.$$

$$\text{Since } u_{xx} + u_{yy} = 0,$$

$$\text{we have } \phi''(F) (F_x^2 + F_y^2) + \phi'(F) (F_{xx} + F_{yy}) = 0,$$

$$\text{i.e. } (F_{xx} + F_{yy}) / (F_x^2 + F_y^2) = -\phi''(F) / \phi'(F).$$

The expression on the right-hand side is a function of F only and so the required condition is that $(F_{xx} + F_{yy}) / (F_x^2 + F_y^2)$ shall be a function of F only. When the condition is satisfied, ϕ can be found by integrating twice.

EXAMPLE 6. Take the concentric circles given by $F(x, y) = x^2 + y^2 = \lambda$, where λ is a variable parameter.

$$\text{Here } (F_{xx} + F_{yy}) / (F_x^2 + F_y^2) = 4/4(x^2 + y^2) = 1/F$$

$$\text{and } \phi''(F) / \phi'(F) = -1/F.$$

This gives

$$\log \phi'(F) = C - \log F$$

or

$$\phi'(F) = A/F$$

and

$$u = \phi(F) = A \log F + B,$$

We have then

$$u = A \log(x^2 + y^2) + B,$$

where A, B are arbitrary constants.

Laplace's Equation in Polar Co-ordinates. If r, θ are the polar co-ordinates of a point whose cartesian co-ordinates are (x, y) , $z = x + iy = r \exp(i\theta)$ and we have

$$u + iv = f(z) = f(r \exp i\theta),$$

where u, v are now expressed in terms of r, θ . Differentiating partially with respect to r and θ , we have

$$u_r + iv_r = f'(z) \exp(i\theta)$$

and

$$u_\theta + iv_\theta = f'(z)ir \exp(i\theta) = ir(u_r + iv_r).$$

Equating real and imaginary parts we find that

$$u_r = (v_\theta)/r \text{ and } u_\theta = -rv_r.$$

Since $(\partial/\partial\theta)u_r = (\partial/\partial r)u_\theta = u_{r\theta}$

and $(\partial/\partial\theta)v_r = (\partial/\partial r)v_\theta = v_{r\theta}$,

we have $(v_{\theta\theta})/r = -v_r - rv_{rr}$, or $v_{rr} + (v_r)/r + (v_{\theta\theta})/r^2 = 0$

and $-(u_{\theta\theta})/r = u_r + rv_{rr} + (u_r)/r + (u_{\theta\theta})/r^2 = 0$. (6)

Thus u and v satisfy the same partial differential equation which is, in fact, Laplace's equation expressed in polar co-ordinates.

As before, the curves $u = \text{constant}$, $v = \text{constant}$ cut orthogonally, and we may apply the method used on p. 55 to find the condition that the equation $F(r, \theta) = \lambda$, in which λ is a variable parameter, should give a u -system.

We have to find the condition that $u = \phi(F)$ satisfies Laplace's equation.

Now

$$u_r = \phi'(F) \cdot F_r, \quad u_\theta = \phi'(F) \cdot F_\theta,$$

$$u_{rr} = \phi''(F) \cdot F_r^2 + \phi'(F) \cdot F_{rr},$$

$$u_{\theta\theta} = \phi''(F) \cdot F_\theta^2 + \phi'(F) \cdot F_{\theta\theta},$$

and, on substituting in equation (6),

$$\phi''(F) (F_r^2 + F_\theta^2/r^2) + \phi'(F) (F_{rr} + F_r/r + F_{\theta\theta}/r^2) = 0.$$

The condition may be written

$$\begin{aligned} (F_{rr} + F_r/r + F_{\theta\theta}/r^2)/(F_r^2 + F_\theta^2/r^2) &= -\phi''(F)/\phi'(F) \\ &= \text{a function of } F \text{ only.} \end{aligned}$$

When the condition is satisfied, ϕ may be found, as before, by integrating twice.

EXAMPLE 7. Show that the equiangular spirals

$$r = k \exp(\theta \cot \alpha)$$

can be a family of stream lines, where α is the same for all the curves and k is a variable parameter.

Here, we take $F = r \exp(-\theta \cot \alpha)$ so that the equation is written in the standard form $F = \text{constant}$.

$$\begin{aligned} \text{Then} \quad F_r &= \exp(-\theta \cot \alpha) = F/r \\ \text{and} \quad F_\theta &= -r \cot \alpha \exp(-\theta \cot \alpha) = -F \cot \alpha, \\ \text{whence} \quad F_{rr} &= 0, \\ \text{and} \quad F_{\theta\theta} &= r \cot^2 \alpha \exp(-\theta \cot \alpha) = F \cot^2 \alpha. \\ \text{Thus} \quad [F_{rr} + (F_r/r) + (F_{\theta\theta}/r^2)]/[F_r^2 + (F_\theta/r)^2] \\ &= [F + F \cot^2 \alpha]/[F^2 + F^2 \cot^2 \alpha] \\ &= 1/F, \end{aligned}$$

which shows that $\phi(F)$ can be found so as to satisfy Laplace's equation, i.e. the spirals can be a family of stream lines. We have

$$\phi''(F)/\phi'(F) = -1/F,$$

$$\begin{aligned} \text{whence} \quad \phi'(F) &= A/F \\ \text{and} \quad \phi(F) &= A \log F + B, \end{aligned}$$

where A and B are real arbitrary constants.

$$\text{Thus} \quad u = \phi(F) = A(\log r - \theta \cot \alpha) + B.$$

It is easily seen that u is the real part of the function

$$w = A \log z + (iA \cot \alpha) \log z + C,$$

where C is a complex constant. The imaginary part of this function is given by

$$v = A\theta + (A \cot \alpha) \log r + D,$$

where D is a real constant. The orthogonal set of curves is given by $v = \text{constant}$, or, more conveniently, by

$$\exp(v \tan \alpha/A) = \text{constant}.$$

These are the equiangular spirals $r = k' \exp(-\theta \tan \alpha)$.

Level Curves. The locus of a point z which moves in the plane of the complex variable z so that the modulus of a function $f(z)$ remains constant is defined as a *level curve* of $f(z)$. The equation of such a curve may be written in the form

$$|f(z)| = M,$$

where M is the constant modulus. By giving M all values from zero to $+\infty$ we obtain an infinite number of curves. Clearly, one and only one of these passes through any given point in the plane.

EXAMPLE 8. When $f(z) = z - a$, the level curves are circles having the point $z = a$ as their common centre.

EXAMPLE 9. For the function $(z - a)/(z - b)$, the level curves are coaxial circles having the points $z = a$, $z = b$ as limiting points. The point-circles of the system are obtained by giving M the values zero and infinity.

EXAMPLE 10. If $f(z) = \exp(z)$, $|f(z)| = \exp(x)$ and the level curves are the straight lines $x = \log_e M$.

EXAMPLE 11. Taking $f(z) = \sin z$, we have

$$\begin{aligned} |f(z)|^2 &= \sin(x + iy) \sin(x - iy) \\ &= (\cosh 2y - \cos 2x)/2 \end{aligned}$$

and the level curves are given by

$$\cosh 2y - \cos 2x = 2M^2,$$

where M ranges from 0 to $+\infty$.

Since $\cosh 2y$ and $\cos 2x$ are both even functions, the curves are symmetrical about both axes of co-ordinates. Also, since $\cos 2x$ is periodic, it is sufficient to trace the curves which lie in the strip bounded by the lines $x = \pm \pi/2$. If M does not exceed unity, the curve meets the x -axis where $\sin x = \pm M$; otherwise the curve does not meet Ox at all. When x vanishes we have $M = |\sin iy| = \pm \sinh y$, according as y is positive or negative. Thus for all values of M the curve meets Oy in two points equidistant from the origin.

Consider the curve for which $M = 1$. Its equation may be reduced to the form $\sinh y = \pm \cos x$.

The curve passes through the points

$$(\pm \pi/2, 0) \text{ and } (0, \pm \log(1 + \sqrt{2})).$$

At each of the first two points it has a node, the tangents at which make angles of $\pi/4$ with Ox .

In Fig. 16 the form of the curves is indicated. When M is less than unity we have a series of ovals with their centres at the points $(n\pi, 0)$, where $n = 0, \pm 1, \pm 2, \dots$. When M is equal to unity we obtain a curve which cuts Ox at the points where x is equal to an odd multiple of $\pi/2$. For values of M greater than unity the curve is in two distinct branches above and below the x -axis.

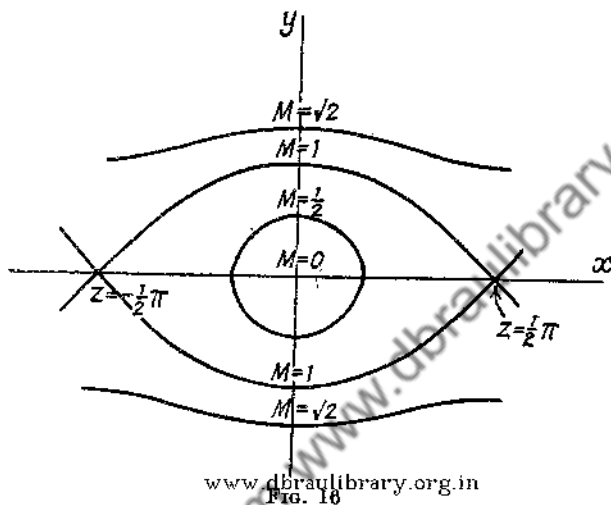

www.dbraulibrary.org.in
Fig. 16

EXAMPLE 12. If $f(z) = \tan z$, we have, as on p. 40,

$$|f(z)|^2 = (\cosh 2y - \cos 2x)/(\cosh 2y + \cos 2x)$$

and the level curve $|f(z)| = M$ is given by

$$\cosh 2y = a \cos 2x,$$

where $a = (1 + M^2)/(1 - M^2)$.

As in the previous example, the curves are symmetrical about both axes, periodic with respect to x , and need only be traced in a strip of width π . We shall take the strip between the lines $x = -\pi/4$ and $x = 3\pi/4$.

When M is less than unity, a is positive and $\cos 2x$ can take only positive values since $\cosh 2y$ is positive for all real values of y . It follows that x lies between $-\pi/4$ and $+\pi/4$. The curve meets each of the axes in two points and is easily seen to be an oval with its centre at the origin. When $M = 0$, the oval reduces to a point.

If $M = 1$, the equation reduces to $\cos 2x = 0$, which gives the straight lines $x = \pm \pi/4, \pm 3\pi/4$, etc.

When $M > 1$, $\cos 2x$ can take only negative values and so x lies between $\pi/4$ and $3\pi/4$. The equation of the curve can be written

$$\cosh 2y = a' \cos 2(x - \pi/2),$$

where $a' = (1 + M'^2)/(1 - M'^2)$ and $M' = 1/M$. The curves are therefore exactly the same in form as those which have

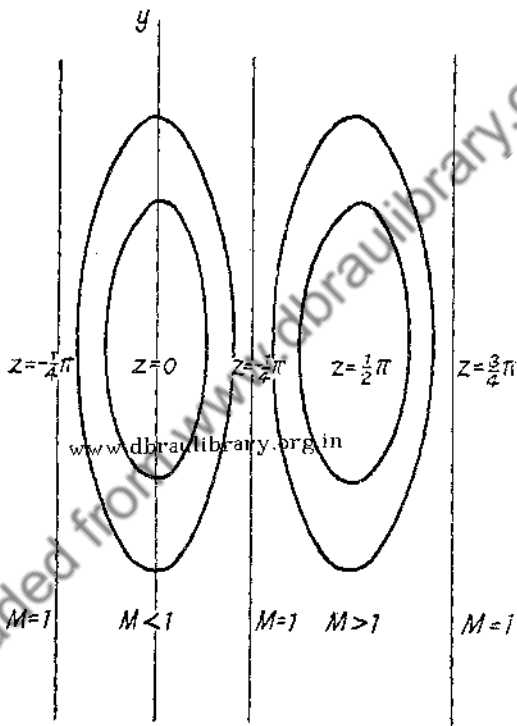

FIG. 17

already been considered. Each has its centre at the point $(\pi/2, 0)$. When M is infinite, M' is zero and the corresponding oval reduces to a point.

The plane is thus divided by the lines $x = (2n + 1)\pi/4$ into strips in which $|\tan z|$ is alternately less than and greater than unity: on the lines, $|\tan z|$ is equal to unity (Fig. 17).

The Surface of Moduli. Suppose that, from the point P , which represents z , PN is drawn perpendicular to and above the z -plane such that $PN = |f(z)|$. Then the points N lie on a surface which may be called the *surface of moduli*. The level curves of the function $f(z)$ are contour lines on this surface, i.e. they are the curves of intersection of the surface by planes parallel to the z -plane.

For z itself, the surface is a right circular cone of which the vertical angle is a right angle; for z^2 the surface is a paraboloid of revolution.

The surface for the function $\tan z$ has an infinite series of hollows and peaks. The lowest points of the hollows are at the points $z = n\pi$ on the z -plane, while the peaks, which are infinitely high, are above the points $z = (n + \frac{1}{2})\pi$, where n is an integer or zero.

These surfaces may be used, as in Jahnke and Emde's Tables, to give a pictorial representation of the values of the modulus of a function of a complex variable.

The Condition that a Given Function $F(x, y)$ should be a Modulus. $F(x, y)$ being a real function of x and y which is not negative for any real values of x and y , suppose that it is the modulus of a function $f(z)$.

Then $f(z) = F \cdot e^{i\alpha}$, where α is the argument of the function and therefore is a real function of x and y .

On taking logarithms we have

$$\log f(z) = \log F + i\alpha$$

and so $\log F$ is the real part of a function of z . From the result on p. 51 it follows that $\log F$ must satisfy Laplace's equation, i.e.

$$(\partial^2/\partial x^2 + \partial^2/\partial y^2) \log F = 0.$$

Conversely, if this condition is satisfied, a function α can be found (by the method given on pp. 51-2) such that $\log F$ and α are conjugate functions. Then

$$\log F + i\alpha = \phi(z), \text{ say,}$$

whence

$$F \cdot \exp(i\alpha) = \exp \phi(z)$$

and F is the modulus of the function on the right-hand side.

The Condition that a Family of Curves should be Level Curves. Suppose that the curves given by the equation

$$G(x, y) = \text{constant}$$

are the level curves for a function $f(z)$,

It does not follow that G is equal to the modulus of $f(z)$; all that we can assume is that $|f(z)|$ is some function of G so that, when $|f(z)|$ is constant, G is constant.

Assume that

$$|f(z)| = \psi(G).$$

It then follows, by the result of the previous section, that

$$(\partial^2/\partial x^2 + \partial^2/\partial y^2) \log \psi(G) = 0.$$

$$\text{Now} \quad (\partial/\partial x) \log \psi(G) = G_x \psi'(G)/\psi(G)$$

and $(\partial^2/\partial x^2) \log \psi(G)$

$$= [G_{xx} \psi'(G)/\psi(G)] + [G_x^2 \psi''(G)/\psi(G)] - [G_x \psi'(G)/\psi(G)]^2.$$

Similarly $(\partial^2/\partial y^2) \log \psi(G)$

$$= [G_{yy} \psi'(G)/\psi(G)] + [G_y^2 \psi''(G)/\psi(G)] - [G_y \psi'(G)/\psi(G)]^2.$$

The condition reduces to

$$\begin{aligned} (G_{xx} + G_{yy})/(G_x^2 + G_y^2) &= [\psi'(G)/\psi(G)] - [\psi''(G)/\psi'(G)], \\ &= - (d/dG) \log [\psi'(G)/\psi(G)]. \end{aligned}$$

It will be noticed that the right-hand side is expressible in terms of G alone. The curves $G = \text{constant}$ are therefore level curves if $(G_{xx} + G_{yy})/(G_x^2 + G_y^2)$ is a function of G only. When the condition is satisfied, ψ may be found by integrating twice.

It will be observed that level curves form a u -system and that the corresponding v -system is given by $\alpha = \text{constant}$.

EXAMPLE 13. If $G = xy$, $G_{xx} + G_{yy}$ vanishes and ψ is given by

$$(d/dG) \log [\psi'(G)/\psi(G)] = 0,$$

whence

$$\psi'(G)/\psi(G) = 2A$$

and

$$\psi(G) = B \exp(2AG)$$

where A and B are arbitrary real constants, the latter being positive.

In order to determine the function $f(z)$, we have to find the conjugate of $\log \psi(G) = 2Axy + \log B$. From Example 1, worked on p. 52, it is easily seen that

$$\log \psi(G) + i\alpha = -iAx^2 + C,$$

where C is an arbitrary constant, in general complex.

The rectangular hyperbolas $xy = \text{constant}$ are therefore the

level curves of the function $\exp(-iAz^2 + C)$, where A and C are constants and the former is real.

Holomorphic Functions. If, for the values of z which are represented by all the points of a region S in the z -plane, a function $f(z)$ is such that (i) it is one-valued, (ii) its values are finite and continuous, and (iii) it is monogenic, then $f(z)$ is said to be *holomorphic* over the region S . The terms *regular* and *analytic* are sometimes used as equivalent to holomorphic.

Clearly the functions z^2 , $\sin z$, and $\exp(z)$ are holomorphic over any region in the finite part of the plane.

Singularities. The function $1/(z - a)$ is holomorphic in any region which does not contain the point $z = a$. At the point $z = a$, the value of the function is not finite. The point is said to be a *singular point* and the function is said to have a *singularity* there.

If the function $f(z)$ is not finite at $z = a$ but is such that a positive integer n can be found so that $(z - a)^n f(z)$ approaches a limit, other than zero, as z approaches a , the function $f(z)$ is said to have a *pole of order n* at the point $z = a$.

According to this definition, $1/(z - a)$ has a pole of order unity, or a *simple pole*, at $z = a$.

Consider the function $\exp(1/z)$, which is holomorphic in any region which does not contain the origin. If P (Fig. 18) represents a positive real value of z , the corresponding value of the function is real and positive and, as P approaches the origin by moving along the real axis, the value of the function increases without limit. If Q represents a negative real value of z , the corresponding value of $1/z$ becomes large and negative as Q moves along the real axis towards O and consequently $\exp(1/z)$ approaches zero. If R is the point iy on the imaginary axis, the corresponding value of the function is $\exp(-iy/y)$, which, for all real values of y , has unit modulus. It is clear then that $\exp(1/z)$ tends to no definite limit as z approaches zero and that no value of n can be found for which $z^n \exp(1/z)$ tends to a limit in like circumstances.

The function $\exp(1/z)$ is therefore said to have an *essential singularity* at the origin.

Since the two types of singularity are of entirely different characters, a pole is sometimes referred to as an *accidental singularity*.



FIG. 18

Curvilinear Integrals. Suppose that x and y are real functions of a parameter t with continuous derivatives dx/dt , dy/dt . Then, as t varies continuously through real values from t_0 to t_1 , the point P whose co-ordinates are (x, y) describes a curve in the xy -plane from the point A , given by $t = t_0$, to B , given by $t = t_1$. For example, if $x = at^2$ and $y = 2at$, the curve is an arc of a parabola; if $x = a \cos t$ and $y = b \sin t$, the curve is an arc of an ellipse. In the latter case, the complete curve is closed and is described once if t_0 and t_1 differ by 2π .

Now let $p(x, y)$ and $q(x, y)$ be continuous functions of x and y . Then the *curvilinear integral*

$$\int_{AB} (p dx + q dy)$$

is defined as equal to the integral

$$\int_{t_0}^{t_1} \left(p \frac{dx}{dt} + q \frac{dy}{dt} \right) dt,$$

where the expression in brackets under the integral sign is a function of t .

From the definition it follows that

$$\int_{AB} (p dx + q dy) = - \int_{BA} (p dx + q dy).$$

By way of illustration, we may take the ellipse given by $x = a \cos t$, $y = b \sin t$, and put $p = -y$, $q = x$. Then

$$\int_{AB} (p dx + q dy) = \int_{t_0}^{t_1} ab(\sin^2 t + \cos^2 t) dt = ab(t_1 - t_0).$$

If $t_1 = t_0 + 2\pi$, the value of the integral is $2\pi ab$, which is twice the area enclosed by the curve. This is a result which is otherwise obvious, since $(x dy - y dx)$ is twice the area of the elemental triangle of which the vertices are the origin and the points (x, y) , $(x + dx, y + dy)$.

Now suppose that $f(z) = u + iv$ is a function of the complex variable $z = x + iy$; then

$$f(z)dz = (u + iv)(dx + idy) = (udx - vdy) + i(vdx + udy)$$

and the integral $\int_{AB} f(z)dz$ is defined as equivalent to

$$\int_{AB} (udx - vdy) + i \int_{AB} (vdx + udy).$$

The curve AB is called the *path of integration*. If the path is a closed curve C the integral is called a *contour integral*.

The contour C is described in the positive sense when a man who walks round it always has the area bounded by C on his left.

Stokes' Theorem. Let C (Fig. 19) be a simple contour in the xy -plane which is met in not more than two points by any straight line parallel to either of the co-ordinate axes. Suppose that the ordinate which is at a distance x from the origin meets C in the points (x, y_1) , (x, y_2) and that the tangents which are parallel to the y -axis are the lines $x = x_1$, $x = x_2$.

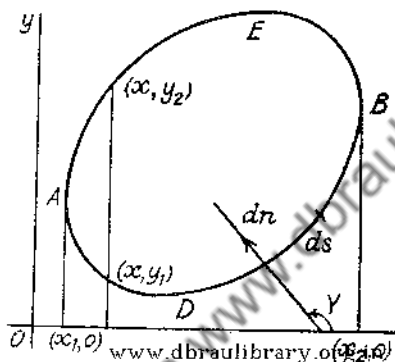

FIG. 19

Let $p(x, y)$ be a function of x, y which, along with its partial derivate $\partial p/\partial y$, is continuous at all points within and on C . Consider the double integral

$$\iint (\partial p/\partial y) dx dy = I$$

taken over the area bounded by C .

Integrating with respect to y , we have

$$I = \int_{x_1}^{x_2} [p(x, y_2) - p(x, y_1)] dx.$$

Now let us take the curvilinear integral $\int_C p dx$, evaluated in the positive sense. Since the contour is made up of the two parts ADB , BEA ,

$$\begin{aligned}
 \int_C p \, dx &= \int_{ADB} p \, dx + \int_{BEA} p \, dx \\
 &= \int_{ADB} p \, dx - \int_{ABE} p \, dx \\
 &= \int_{x_1}^{x_2} [p(x, y_1) - p(x, y_2)] dx \\
 &= -I.
 \end{aligned}$$

Similarly, if q and $\partial q/\partial x$ are continuous at all points within and on C , it may be shown that

$$\int_C q \, dy = \iint (\partial q/\partial x) dx dy,$$

where the double integral is evaluated over the same area.

On adding the two results we have the two-dimensional form of *Stokes's Theorem*

$$\int_C (p \, dx + q \, dy) = \iint [(\partial q/\partial x) - (\partial p/\partial y)] dx dy,$$

where the double integral is evaluated over the area bounded by C .

If the contour is met in more than two points by lines parallel to the axes, it may be subdivided into areas bounded by contours of the simpler type considered above. The theorem is true for each of these contours and, by addition, it follows that the result is true for the more complicated contour. (A line which forms a boundary between two adjacent areas will be described twice—once in each direction—in the contour integrals, and so contributes nothing to their sum.)

Cauchy's Theorem. Let $f(z) = u + iv$ be a function of z which is holomorphic at all points within and on a contour C in the z -plane. Using the result on p. 64 and applying Stokes's theorem, we have

$$\begin{aligned}
 \int_C f(z) dz &= \int_C (u \, dx - v \, dy) + i \int_C (v \, dx + u \, dy) \\
 &= \iint (-v_x - u_y) dx dy + i \iint (u_x - v_y) dx dy,
 \end{aligned}$$

where the double integrals are evaluated over the area bounded by C , and suffixes denote partial derivatives.

Since u and v are the real and imaginary parts of a function of z , we have $u_x = v_y$ and $u_y = -v_x$. That is to say, both double integrals vanish and we have the important result, due to Cauchy, that

$$\int_C f(z) dz = 0,$$

i.e. the integral of a function of z taken round any contour in the z -plane, within and on which the function is holomorphic, is zero.

Suppose that z_0 and z_1 are two points which can be connected by two paths L and L' such that, at all points between and on L and L' , $f(z)$ is holomorphic. From the above theorem it follows that the integral of $f(z)$ from z_0 to z_1 by the path L , together with the integral from z_1 to z_0 by the path L' , is zero. Therefore the integrals taken from z_0 to z_1 by the two paths

are equal: in other words, the value of the integral $\int_{z_0}^{z_1} f(z) dz$ is the same for any two paths which do not pass through, nor enclose between them, any singularity of the function $f(z)$.

Rational Functions. A function of the form $P(z)/Q(z)$, where P and Q are polynomials in z , is said to be a *rational function* of z . It may be assumed that the numerator and denominator have no common factor, otherwise the expression could be simplified by the cancellation of that factor.

For instance, the functions $3z^2 + 2$, $1/z$, $(2z^3 + 1)/(z^2 + z)$ are rational.

Suppose that the polynomials $P(z)$, $Q(z)$ are of degrees m , n , respectively. Then, if m is not less than n , we can divide $Q(z)$ into $P(z)$ and obtain a quotient $F(z)$, which is a polynomial of degree $m - n$, and a remainder $G(z)$, which is a polynomial of degree less than n . Thus

$$P(z)/Q(z) = F(z) + [G(z)/Q(z)],$$

where the fraction on the right-hand side is *proper*, i.e. the numerator is of lower degree than the denominator. If $m = n$, the quotient $F(z)$ is a mere constant.

The polynomial $Q(z)$ may be factorized in the form

$$k(z - \alpha)^a (z - \beta)^b \dots (z - \rho)^r,$$

where k is independent of z , where $\alpha, \beta, \dots, \rho$ are the zeros and where a, b, \dots, r are positive integers whose sum is equal

to n , the degree of $Q(z)$. If none of the zeros occurs more than once, the indices a, b, \dots, r are each unity.

Clearly, the only finite values of z for which the function is not finite are $\alpha, \beta, \dots, \rho$. If $P(z)$ is of degree m , then if m is less than n , the function becomes zero when z becomes infinite; if m is equal to n , the function approaches a finite limit as z tends to infinity, but, if m exceeds n , the function is infinite when z is infinite.

Thus the only singularities of the rational function $P(z)/Q(z)$ in the finite part of the z plane are at the points $\alpha, \beta, \dots, \rho$, where it has poles of orders a, b, \dots, r , respectively.

Using the ordinary methods of resolution into partial fractions, we may write

$$\begin{aligned} P(z)/Q(z) &= F(z) + A_1(z-\alpha)^{-1} + A_2(z-\alpha)^{-2} + \dots + A_a(z-\alpha)^{-a} \\ &\quad + B_1(z-\beta)^{-1} + B_2(z-\beta)^{-2} + \dots + B_b(z-\beta)^{-b} \\ &\quad + \dots + R_1(z-\rho)^{-1} + R_2(z-\rho)^{-2} + \dots + R_r(z-\rho)^{-r}, \end{aligned}$$

where $F(z)$ is zero if P is of lower degree than Q and $F(z)$ is a polynomial of degree $m-n$ (actually the quotient obtained by dividing Q into P) if m is not less than n .

With centre at the point α , describe a circle C whose radius R is less than the distance between α and the nearest of the points $\beta, \gamma, \dots, \rho$. Then, within and on this circle, the function

$$\phi(z) = P(z)/Q(z) - A_1(z-\alpha)^{-1} - A_2(z-\alpha)^{-2} - \dots - A_a(z-\alpha)^{-a}$$

is holomorphic and therefore its integral round the circle vanishes.

If z is any point on the circle, we have $z - \alpha = R \exp(i\theta)$ and $dz = iR \exp(i\theta)d\theta$, from which we have

$$\begin{aligned} \int_C A_1(z-\alpha)^{-1} dz &= \int_0^{2\pi} iA_1 d\theta = 2\pi i A_1 \\ \text{and } \int_C A_s(z-\alpha)^{-s} dz &= \int_0^{2\pi} iA_s R^{1-s} [\exp(1-s)i\theta] d\theta \\ &= \left[\frac{A_s R^{1-s}}{1-s} [\exp(1-s)i\theta] \right]_0^{2\pi} \\ &= 0, \end{aligned}$$

where $s = 2, 3, \dots, a$.

Therefore
$$\int_C \phi(z) dz = \int_C [P(z)/Q(z)] dz - 2\pi i A_1 = 0$$

and
$$\int_C [P(z)/Q(z)] dz = 2\pi i A_1.$$

The constant A_1 is defined as the *residue* of the function at the pole α . Note that if α is a simple pole, A_1 is the limit of $(z - \alpha)P(z)/Q(z)$ as z tends to α .

If C' is any simple closed contour surrounding the pole α but not containing any other pole of the function, we can draw a circle C lying within C' and having its centre at α . By Cauchy's theorem, the integral of the function taken round C' is equal to the integral taken round C and we can conclude that the integral taken round a contour which contains within it one and only one pole is equal to $2\pi i$ multiplied by the residue at that pole.

Now let S be any closed contour containing within it any number of the poles, say, $\alpha, \beta, \dots, \lambda$, at which the residues are A_1, B_1, \dots, L_1 . Surround each of these points by a circle which contains within it no other pole and connect each of these circles to S by a path which does not meet any of the other circles or paths, as in Fig. 20.

The function $f(z) = P(z)/Q(z)$ is holomorphic at all points of the region between S and the circles and therefore

$$\int f(z) dz = 0$$

when the integral is taken round the complete boundary of the region as indicated by the arrows. Each connecting path is described twice—once in each sense—and so contributes nothing to the value of the integral.

It follows that

$$\int_S f(z) dz$$

minus the sum of the integrals taken round the circles in the positive sense is zero.

Hence
$$\int_S f(z) dz = 2\pi i (A_1 + B_1 + \dots + L_1),$$

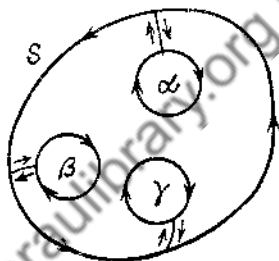

FIG. 20

i.e. the integral taken in the positive sense round any contour is equal to $2\pi i$ multiplied by the sum of the residues at the poles within the contour.

EXAMPLE 14. If $P(z) = z - 1$ and $Q(z) = z + 1$, then $f(z) = 1 - 2(z + 1)^{-1}$. The only singularity of $f(z)$ is a simple pole at $z = -1$, the residue being -2 . Hence $\int_C f(z) dz$ is zero if the contour C does not surround the point $z = -1$ but is equal to $-4\pi i$ if C encloses this point.

Let C be the circle $|z| = 2$. Then, on the circle, $z = 2 \exp i\theta$, and $dz = 2i(\exp i\theta)d\theta$; therefore

$$\begin{aligned} \int_C f(z) dz &= 2i \int_0^{2\pi} \{\exp i\theta - 2[(\exp i\theta)/(1 + 2 \exp i\theta)]\} d\theta \\ &= 2i \int_0^{2\pi} \{\exp i\theta - 2[(\exp i\theta + 2)/(5 + 4 \cos \theta)]\} d\theta \\ &= 2i \int_0^{2\pi} \{\cos \theta + i \sin \theta - 2[(\cos \theta + i \sin \theta + 2)/(5 + 4 \cos \theta)]\} d\theta \\ &= -4\pi i. \end{aligned}$$

By equating real and imaginary parts, we have

$$\int_0^{2\pi} [(\cos \theta + 2)/(5 + 4 \cos \theta)] d\theta = \pi$$

and

$$\int_0^{2\pi} [\sin \theta / (5 + 4 \cos \theta)] d\theta = 0.$$

The value of the second integral is otherwise obvious but that of the first would be more troublesome to find by more elementary methods.

EXAMPLE 15. Evaluate $\int_0^{2\pi} (1 - 2k \cos \theta + k^2)^{-1} d\theta$, where k is real, positive, and less than unity.

Writing z for $\exp(i\theta)$, we have $\cos \theta = (z + z^{-1})/2$ and $d\theta = dz/iz$.

As θ varies from 0 to 2π , the point z describes the circle of radius unity which has its centre at the origin. The given integral is therefore equal to the contour integral

$$\int \frac{dz}{iz(1 - kz)(1 - k/z)} = \int \frac{dz}{i(1 - kz)(z - k)}$$

taken round the unit circle in the positive sense.

The integrand is a rational function with simple poles at $z = k$ and $z = 1/k$, and of these, only the former lies within the circle. The residue at $z = k$ is the limit, as z tends to k , of

$$\frac{z - k}{i(1 - kz)(z - k)}, \text{ which is } 1/i(1 - k^2).$$

Therefore the integral is equal to $2\pi/(1 - k^2)$.

Taylor and Laurent Series for Rational Functions. Let c be any finite number which is not a zero of $Q(z)$. With the point $z = c$ as centre and radius equal to the distance between this point and the nearest zero of $Q(z)$ describe a circle S . Then the function $P(z)/Q(z)$ is holomorphic at all points within (but not on) S .

If z is any point within S ,

$$\begin{aligned} (z - \alpha)^{-k} &= [(z - c) + (c - \alpha)]^{-k} \\ &= (c - \alpha)^{-k} \{1 + [(z - c)/(c - \alpha)]\}^{-k} \\ &= (c - \alpha)^{-k} \left[1 + \sum_{r=1}^{\infty} A_r (z - c)^r\right], \end{aligned}$$

where k is any one of the integers $1, 2, 3, \dots, a$ and

$$A_r = -k(-k-1)(-k-2)\dots(-k-r+1)/r!(c-\alpha)^r.$$

We have used the binomial expansion, which is valid since $|(z - c)/(c - \alpha)|$ is less than unity.

Similarly, all the other terms containing negative indices may be expanded as power series in $z - c$. The polynomial $P(z)$ can be expressed as the sum of a finite number of positive powers of $z - c$.

Hence, if the point z lies within the circle S ,

$$P(z)/Q(z) = \sum_{r=0}^{\infty} C_r (z - c)^r.$$

The series on the right is called a *Taylor series*.

We shall now consider the type of series which is obtained when, instead of an ordinary point c , we take one of the poles of the function, say α .

Let T, T' be two circles which have the point $z = \alpha$ as common centre, the radius of the outer (T) being equal to the distance between α and the nearest of the other zeros (β, γ, \dots) of $Q(z)$. Then the rational function

$$P(z)/Q(z) = A_1(z - \alpha)^{-1} - A_2(z - \alpha)^{-2} - \dots - A_a(z - \alpha)^{-a}$$

is holomorphic at all points within T and therefore can be expanded in a Taylor series of the form

$$\sum_{r=0}^{\infty} C_r(z-\alpha)^r.$$

It follows that, if the point z lies within the annulus bounded by T and T' ,

$$P(z)/Q(z) = \sum_{s=1}^a A_s(z-\alpha)^{-s} + \sum_{r=0}^{\infty} C_r(z-\alpha)^r.$$

Such a series is known as a *Laurent series*. The terms containing negative powers of $z-\alpha$, viz. $\sum_{s=1}^a A_s(z-\alpha)^{-s}$, are said to form the *principal part* of the series. It should be noted that A_1 is the residue at the pole α , which is of order a .

EXAMPLE 16. For the function $f(z) = (2z^3 + 1)/(z^2 + z)$ find a Taylor series valid in the neighbourhood of the point $z = i$ and a Laurent series valid within an annulus of which the centre is the origin.

By division and the use of partial fractions, we have

$$f(z) = 2z - 2 + (2z + 1)/(z^2 + z) = 2z - 2 + (1/z) + 1/(z + 1),$$

from which it is seen that the function has simple poles at the points $z = 0$, $z = -1$, the residues being unity.

Since the function is finite when $z = i$, there is a Taylor series valid within the circle which has its centre at that point, the radius being the distance between $z = i$ and the origin, which is the nearer of the two poles.

Writing t for $z - i$, we have

$$\begin{aligned} f(z) &= 2i - 2 + 2t + 1/(i + t) + 1/(1 + i + t) \\ &= 2i - 2 + 2t - i \sum_{n=0}^{\infty} (it)^n + \frac{1}{2}(1 - i) \sum_{n=0}^{\infty} [(i - 1)t]^n \end{aligned}$$

as the Taylor series. It is valid within the unit circle which has its centre at the point $z = i$.

There is a simple pole at the origin and the other pole is at unit distance from this. Hence there is a Laurent series valid within the annulus, which has its centre at the origin and outer radius unity; the inner radius can have any value smaller than this.

The point z being anywhere within the annulus, $|z| < 1$ and

so $1/(z \pm 1)$ may be expanded as a geometric series of ascending powers of z . Thus the required Laurent series is

$$\begin{aligned} (1/z) - 2 + 2z + \sum_{n=0}^{\infty} (-z)^n \\ = (1/z) - 1 + z + \sum_{n=2}^{\infty} (-z)^n \end{aligned}$$

The principal part of the series is $1/z$.

Behaviour of a Rational Function at Infinity. In order to determine the behaviour of a rational function $f(z) = P(z)/Q(z)$ when z becomes infinite, we substitute Z for $1/z$ and consider how the resulting function of Z behaves when Z becomes zero. Two different cases arise.

Case i. If the degree of $P(z)$ is not greater than that of $Q(z)$, $f(1/Z)$ is finite when $Z = 0$ and can be expanded therefore in a Taylor series. Thus

$$f(1/Z) = A_0 + A_1Z + A_2Z^2 + \dots$$

when $|Z|$ is sufficiently small, and therefore

$$f(z) = A_0 + (A_1/z) + (A_2/z^2) + \dots$$

when $|z|$ is sufficiently great.

Since, in this case, $f(z)$ is finite when z is infinite, the point at infinity is said to be an ordinary point of the function.

Case ii. If the degree of $P(z)$ is greater than that of $Q(z)$, $f(1/Z)$ becomes infinite when $Z = 0$, i.e. it has a pole of order p , say. Then, if Z lies within an annulus with its centre at the origin in the Z -plane,

$$f(1/Z) = \sum_{s=1}^p B_s Z^{-s} + \sum_{r=0}^{\infty} C_r Z^r.$$

The outer radius (R) of the annulus is fixed and the inner radius may be made as small as we please.

Hence,
$$f(z) = \sum_{s=1}^p B_s z^s + \sum_{r=0}^{\infty} C_r z^{-r}$$

when $|z| > 1/R$.

In this case we say that the function has a pole of order p at infinity, the principal part of the expansion there being

$$\sum_{s=1}^p B_s z^s$$

EXAMPLE 17. Consider the function $f(z)$ of Example 16, p. 72. We have

$$\begin{aligned} f(1/Z) &= (2/Z) - 2 + Z + Z/(1 + Z) \\ &= (2/Z) - 2 + Z + Z(1 - Z + Z^2 - Z^3 + \dots), \end{aligned}$$

provided that $|Z| < 1$. It follows that the function has a simple pole at $Z = 0$, and therefore the function $f(z)$ has a simple pole at infinity. Hence

$$f(z) = 2z - 2 + 2z^{-1} - z^{-2} + z^{-3} - \dots,$$

when $|z| > 1$. The principal part of the expansion is $2z$.

Analogous Results for Functions in General. Having considered in some detail the properties of the rational function, we now state analogous properties of functions which are not necessarily rational. No proofs are given here as they are beyond the scope of this book. They will be found in the more comprehensive treatises to which reference is made in the Appendix (p. 135).

I. *Taylor's Theorem.* A function $f(z)$, which is holomorphic at all points within a circle of radius r and centre $z = a$, can be represented by a series

$$f(z) = f(a) + (z-a)f'(a) + \frac{(z-a)^2}{2!}f''(a) + \dots$$

valid when $|z-a| < r$, where $f_n(a)$ denotes the value of $(d/dz)^n f(z)$ when $z = a$.

II. *Laurent's Theorem.* If $f(z)$ is holomorphic at all points within an annulus bounded by two circles, with the point $z = a$ as common centre, and with radii R, r , such that r may be made as small as we please, then, if z is any point within the annulus,

$$f(z) = \sum_{n=0}^{\infty} A_n(z-a)^n + \sum_{n=1}^{\infty} B_n(z-a)^{-n}.$$

If B_n vanishes when n exceeds s but B_s is not zero, it is said that the point a is a pole of order s and that the residue there is B_1 . At a simple pole s is unity and the residue is the limit of $(z-a)f(z)$ when z tends to a .

If an infinite number of the coefficients B are different from zero, the point a is said to be an *essential singularity*.

III. *The Contour Integration Theorem.* If $f(z)$ is holomorphic

at all points on a simple closed contour C , which contains within it no singularities of $f(z)$ other than poles, then

$$\int_C f(z) dz = 2\pi i R,$$

where R is the sum of the residues at the poles within C and where the integral is taken in the positive sense with respect to the area within C .

IV. *Behaviour at Infinity.* To discuss the behaviour of $f(z)$ when z becomes infinite, we write $z = 1/Z$ and consider how $f(1/Z)$ behaves when Z approaches zero.

EXAMPLE 18. The function $f(z) = \exp(z)$ is finite when z is finite, but is singular in its behaviour when z becomes infinite. Thus, if z is increased without limit through positive real values, $f(z)$ becomes infinite, whereas, if z approaches infinity through negative real values, $f(z)$ tends to zero.

Putting $z = 1/Z$, we have

$$f(1/Z) = \sum_{n=0}^{\infty} (Z^{-n}/n!),$$

the series on the right being a Laurent series which contains an unlimited number of terms involving negative powers of Z . The function $f(1/Z)$ therefore has an essential singularity at $Z = 0$, and it follows that the function $\exp(z)$ has an essential singularity at infinity.

EXAMPLE 19. Consider the function $f(z) = \exp(z)/z$. This is finite in the z -plane at all points except the origin and at infinity. When z is finite and not zero,

$$\begin{aligned} f(z) &= \sum_{n=0}^{\infty} z^{n-1}/n! \\ &= (1/z) + 1 + (z/2!) + (z^2/3!) + \dots \end{aligned}$$

Thus the function has a Laurent series valid within an annulus with the origin as centre, the radius of the inner circular boundary being as small as we please. Since the only term which involves a negative power of z is $1/z$, the function has a simple pole at the origin with a residue of unity.

Again, $f(1/Z) = Z + 1 + (Z^{-1}/2!) + (Z^{-2}/3!) + \dots$

from which it is seen that the function $f(1/Z)$ has an essential singularity at $Z = 0$ and therefore $\exp(z)/z$ has an essential singularity at infinity.

If we draw any simple contour C which encloses the origin, the integral of the function round the contour in the positive sense is equal to $2\pi i$, because the residue at the pole is unity. If C is the circle $z = 1$, we have $z = \exp(i\theta)$ at any point on C and

$$\begin{aligned} 2\pi i &= \int_C f(z) dz \\ &= \int_{-\pi}^{\pi} \exp(\cos \theta + i \sin \theta) i d\theta \\ &= i \int_{-\pi}^{\pi} \exp(\cos \theta) \cos(\sin \theta) d\theta - \int_{-\pi}^{\pi} \exp(\cos \theta) \sin(\sin \theta) d\theta. \end{aligned}$$

By equating imaginary parts, we deduce that

$$\int_{-\pi}^{\pi} \exp(\cos \theta) \cos(\sin \theta) d\theta = 2\pi,$$

from which it follows that

$$\int_0^{\pi} \exp(\cos \theta) \cos(\sin \theta) d\theta = \pi,$$

because the integrand is an even function of θ .

On equating real parts, we see that the other integral vanishes—a result which is otherwise obvious since the integrand is an odd function of θ .

EXAMPLE 20. A function $f(z)$ is holomorphic at all points, except $z = a$, within a circle $|z - a| = R$, and $(z - a)f(z)$ tends to a limit k as z approaches a . If A and B are points on the circle $|z - a| = r (< R)$ such that the arc AB (described in the positive sense from A to B) subtends an angle ϕ at a , prove that, as r tends to zero, $\int f(z) dz$, taken along the arc from A to B , approaches the limit $ik\phi$.

First we consider $I_1 = \int [k/(z - a)] dz$, taken along the arc AB . When z is on this arc,

$$z - a = r \exp(i\theta), \text{ and } dz = ir \exp(i\theta) d\theta,$$

and, whatever be the value of r ,

$$I_1 = ik \int d\theta = ik\phi.$$

Since $(z - a)f(z)$ tends to the limit k as z approaches a , we can choose r so small that, when z is on the arc AB ,

$$(z - a)f(z) - k = \eta,$$

where $|\eta| < \varepsilon$ and ε is any given positive number no matter how small.

$$\text{Hence } f(z) - [k/(z - a)] = \eta/(z - a)$$

$$\text{and } I - I_1 = \int [\eta/(z - a)] dz = i \int \eta d\theta,$$

where I stands for $\int f(z) dz$.

$$\text{Therefore } |I - I_1| = \left| \int \eta d\theta \right| < \varepsilon \int d\theta = \varepsilon \phi.$$

By making r sufficiently small, it follows that we can make $|I - I_1|$ as small as we please, i.e. in the limit

$$I = I_1 = ik\phi.$$

EXERCISES

1. (i) Show geometrically that $x - iy$, $|z|$ and $\arg z$ are not monogenic functions of z .

(ii) If w is a monogenic function of z , show that dw/dz is also a monogenic function of z .

2. Show that $\log z$ and $\tanh z$ are monogenic functions of z .

3. Using Euler's theorem that, if u is a function of x, y which is homogeneous of degree m , $xu_x + yu_y = mu$, show that, if u also satisfies Laplace's equation, it is the real part of a function $f(z)$ such that $f(z) = u + (im)(yu_x - xu_y)$.

Determine $f(z)$ when (i) $u = x^3 - 3xy^2$; (ii) $v = y/(x^2 + y^2)$;

(iii) $u = ax^3 + 2bxy - ay^3$; (iv) $u = xy/(x^2 + y^4)$.

4. If u, v are conjugate, show that the following are also conjugate: (i) $au - bv$ and $av + bu$, where a, b are real constants; (ii) $u/(u^2 + v^2)$ and $-v/(u^2 + v^2)$.

5. Find a pair of conjugate functions u and v such that

$$u + v = [(x - y) \sin 2x - (x + y) \sinh 2y]/(\cos 2x + \cosh 2y)$$

and such that v is zero when y is zero.

6. Show that the curves given by $r = \lambda \cos n\theta$, where λ is a variable parameter, form a u -system only when $n = 0$ or 1 .

7. Show that the parabolas $r = \lambda(1 + \cos \theta)$ form a u -system and find the corresponding v -system.

8. In a two-dimensional gravitational field the equipotential lines are given by the equation $rr' = \text{constant}$, where r and r' are the distances

of a point from two fixed points A and B . Prove that the lines of force are rectangular hyperbolas which pass through A and B .

9. Show that the coaxial circles given by $x^2 + y^2 + 2\lambda x + c = 0$, where λ is a variable parameter and c is the same for all the circles, can be a family of lines of force (or stream lines) and find the corresponding equipotentials.

10. A plane curve is determined by the parametric equations $x = f(t)$, $y = g(t)$. Show that the curve is one of the v -system given by the relation $z = f(w) + ig(w)$.

For the ellipse $x = a \cos t$, $y = b \sin t$, show that the v -system consists of the family of confocal ellipses.

Find the u - and v -systems when the curve is the parabola

$$x = at^2, y = 2at.$$

11. If $u + iv = \log(z - a) - \log(z + a)$, show that the curves $u = \text{constant}$ and $v = \text{constant}$ are two sets of circles which cut orthogonally.

12. If $z = \tan w$, prove that $x(\cos 2u + \cosh 2v) = \sin 2u$ and $y(\cos 2u + \cosh 2v) = \sinh 2v$. Hence show that if u is constant and v varies, z describes, on the Argand diagram, the circle

$$x^2 + y^2 + 2x \cot 2u = 1.$$

13. Express $w = z(z + i)/(z - i)$ in the form $a + ib$. Determine the regions of the plane within which the modulus of the function $\exp(w)$ is greater than unity. (U.L.)

14. Sketch the level curves for the functions—

- | | |
|--|--------------------|
| (i) $\sin z - \sin a$, where a is real; | (iv) $\exp(1/z)$; |
| (ii) $\exp(z) - 1$; | (v) $\log z$; |
| (iii) $z \exp(z)$; | (vi) $\exp(z)/z$. |

15. If $f(z) = (z^2 + 1)/z$ and z' is the inverse point of z with respect to the unit circle with the origin as centre, prove that $|f(z')| = |f(z)|$.

Sketch the level curves for $f(z)$. Show that the curve $|f(z)| = M$ meets the circle in four real points if $M \leq 2$, but that, if $M > 2$, the curve consists of an oval within the circle and of the inverse of this oval with respect to the circle.

16. Evaluate the integral $\int \exp(nz)/(2z^2 - i) dz$ taken separately, in the positive sense, round each of the four quadrants of the circle $|z| = 1$ determined by the axes. (U.L.)

17. If $f(z)$ is holomorphic at all points within and on a simple contour C , show that the value of $\int_C f(z)/(z - a) dz$ is zero, if the point a is outside, and $2\pi i f(a)$, if a is within C .

18. Evaluate $\int \exp[(a + ib)x] dx$ and deduce that

$$(a^2 + b^2) \int e^{ax} \cos bx dx = e^{ax}(a \cos bx + b \sin bx)$$

and $(a^2 + b^2) \int e^{ax} \sin bx dx = e^{ax}(a \sin bx - b \cos bx).$

CHAPTER V

CONFORMAL TRANSFORMATION

Conformal Transformation. Suppose that two complex variables $w = u + iv$ and $z = x + iy$ are connected by the relation

$$w = f(z),$$

where $f(z)$ is a monogenic function of z .

Corresponding values of z and w will be represented by points in two planes which we shall call the z - and w -planes respectively. If P , in the former plane, represents a value of z for which $f(z)$ is finite and its derivate is finite and not zero, P will be called an *ordinary point*. The corresponding value of w will

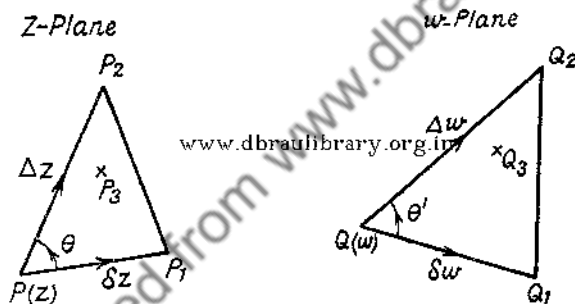

FIG. 21

be represented by a point Q at a finite distance from the origin in the w -plane. Let P_1, P_2 (Fig. 21) be ordinary points near to P representing $z + \delta z, z + \Delta z$, respectively, and let Q_1, Q_2 be the corresponding points in the w -plane representing $w + \delta w = f(z + \delta z)$ and $w + \Delta w = f(z + \Delta z)$.

Since w has a unique derivate with respect to z , both $\delta w/\delta z$ and $\Delta w/\Delta z$ approach the same limit dw/dz as PP_1 and PP_2 are diminished to zero. If PP_1 and PP_2 are sufficiently small, we shall have

$$\delta w/\delta z = \Delta w/\Delta z$$

and therefore

$$\Delta z/\delta z = \Delta w/\delta w;$$

i.e.

$$(PP_2/PP_1)e^{i\theta} = (QQ_2/QQ_1)e^{i\theta'},$$

where θ, θ' are the angles P_1PP_2, Q_1QQ_2 respectively.

It follows that

$$PP_2/PP_1 = QQ_2/QQ_1 \text{ and } \theta = \theta'.$$

Thus the two infinitesimal triangles PP_1P_2 , QQ_1Q_2 are directly similar, their linear dimensions being in the ratio $1:|dw/dz|$ and their areas in the ratio $1:|dw/dz|^2$. The factor $|dw/dz|$ is defined as the *magnification*.

If P_3 is any point within the triangle PP_1P_2 , the corresponding point Q_3 will be such that the triangles PP_1P_3 , QQ_1Q_3 are directly similar, and, consequently, Q_3 lies within the triangle QQ_1Q_2 .

The relation transforms the infinitesimal triangle PP_1P_2 in the z -plane, into a directly similar triangle QQ_1Q_2 , in the w -plane, and points within the first correspond to points within the second triangle. A point which moves round the perimeter of the first triangle in the positive sense is transformed into a point which describes the perimeter of the second triangle *in the same sense*.

If a point moves in the z -plane so as to trace a curve, the locus of the corresponding point in the w -plane is called the transformed curve. If PP_1 , PP_2 are elements of arc of two curves through P , then QQ_1 , QQ_2 are the corresponding elements of arc of the transformed curves, and, as we have seen, the angles P_1PP_2 , Q_1QQ_2 are equal in both magnitude and sense. The transformed curves therefore intersect at the same angle as the original ones. In particular, orthogonal curves transform into orthogonal curves.

Suppose that C is a simple closed curve in the z -plane such that all points on and within it are ordinary points for the transformation. Let D be the corresponding curve in the w -plane. Then D is also a closed curve since $f(z)$ is assumed to be one-valued. The area bounded by C may be divided into infinitesimal triangles which transform into directly similar triangles in the w -plane and the aggregate of the latter triangles is the area bounded by D . But the curves C and D are not, in general, similar, for the magnification is not constant over the area but varies from point to point.

Since infinitesimal elements of area are unaltered in shape, the transformation is said to be *conformal*.

It is important to notice that the above discussion has been limited to ordinary points: it is to be expected that the

conformal property will be lacking at points which are not ordinary but are *singular*.

EXAMPLE 1. Consider the curves $u=\text{constant}$, $v=\text{constant}$ in the z -plane. The corresponding curves in the w -plane are the two families of straight lines parallel to the v - and u -axes and these obviously intersect at right angles. The curves $u=\text{constant}$ and $v=\text{constant}$ therefore cut orthogonally—a fact which was seen in the previous chapter.

EXAMPLE 2. Apply the transformation $w = z^2$ to the area in the first quadrant of the z -plane bounded by the axes and the circles $|z| = a$, $|z| = b$ ($a > b > 0$).

If $z = re^{i\theta}$, then $w = r^2e^{2i\theta}$ and so $w = r^2$ and $\arg w = 2\theta$. The quadrantal arcs AA' , BB' therefore become semicircular

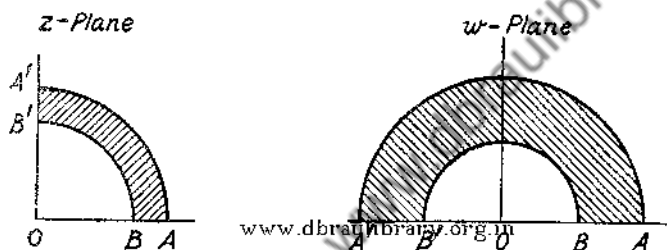

FIG. 22

arcs of radii a^2 , b^2 respectively, while the straight lines AB , $A'B'$ become the parts of the u -axis between the points $w = a^2$, $w = b^2$ and $w = -a^2$, $w = -b^2$.

In Fig. 22, corresponding points in the two planes are indicated by the same letter. The magnification at any point is given by $|dw/dz| = 2|z|$ and is finite and different from zero at all points within and on the given boundary. The transformation is therefore conformal; e.g. the angles at A , B , A' , B' in both figures are right angles. But if b vanishes, so that the area in the z -plane becomes the quadrant OAA' , the corresponding area in the w -plane is the semicircle on AA' as diameter and the transformation is conformal everywhere except at O , where the magnification vanishes. The angles at O in the two planes are *not* equal, that in the z -plane being $\pi/2$ and the other being π . But the angles at the points A , A' are still right angles.

EXAMPLE 3. Consider the transformation $w = az$, where a is a complex constant.

Let $a = A \exp(i\alpha)$ and $z = r \exp(i\theta)$.

Then $w = Ar \exp(i\theta + i\alpha)$, $|w| = A|z|$

and $\arg w = \arg z + \arg a$.

If P , in the z -plane, represents z , the point Q , in the same plane, which represents the corresponding value of w , may be constructed by rotating OP about O through an angle α in the positive sense and then altering its length in the ratio $A:1$. In other words, the transformation is equivalent to a rotation about a point and a magnification. If P describes a curve, the locus of Q is a geometrically similar curve turned through an angle α .

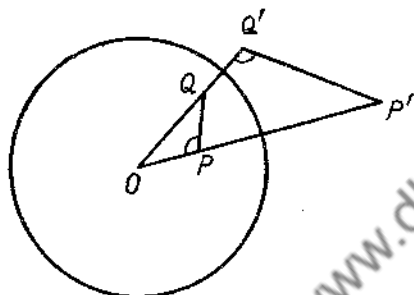

FIG. 23. www.dbraulibrary.org

respect to the circle. The point O is called the centre of inversion and k the radius of inversion. Clearly, if P is outside the circle, P' is inside the circle; if P' is on the circle P coincides with P .

If Q, Q' are any other pair of inverse points with respect to the same circle, the triangles $OPQ, OQ'P'$ are similar because $OP/OQ = OQ'/OP'$ and the angle at O is common to the two triangles. It follows that the angles OPQ and $OQ'P'$ are equal.

If P moves in the plane so as to describe a curve C , its inverse P' describes a curve C' which is defined as the inverse of C . Suppose that P and Q are neighbouring points on C so that PQ is an element of arc of the curve; then P' and Q' are neighbouring points on C' . As Q approaches P , the limiting position of the chord PQ is the tangent at P to the curve C , while that of $P'Q'$ is the tangent to C' at the point P' . These two tangents thus make equal angles with OP (measured in opposite senses). It easily follows that, if two curves C, D intersect at an angle θ , their inverses also intersect at an

angle θ . In particular, the inverses of two orthogonal curves are also orthogonal.

If O is the origin and P the point $z = r \exp(i\theta)$ in the z -plane, then $OP' = k^2/OP$ and P' represents $(k^2/r) \exp(i\theta)$. Let P_1 be the image of P' in the real axis; then P_1 represents

$$(k^2/r) \exp(-i\theta) = k^2/\bar{z}.$$

If P describes the curve C , the locus of P_1 is the reflexion of the inverse curve C' .

Consider the inverse of a circle of radius a with its centre at the point A (Fig. 24). Let P be any point on the circumference

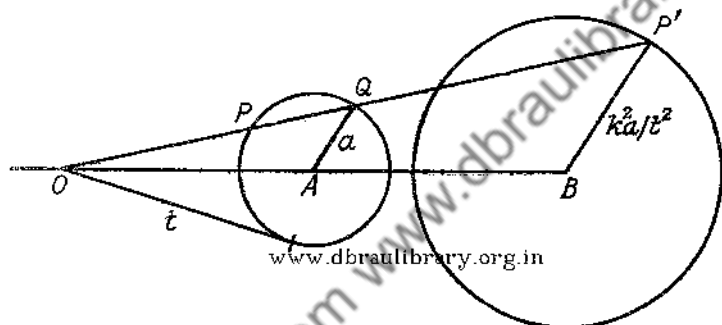

FIG. 24

and let OP meet the circle again at Q . Draw a line through P' , the inverse of P , parallel to AQ to meet OA in B . Then

$$OB/OA = OP'/OQ = OP \cdot OP'/OP \cdot OQ = k^2/t^2,$$

where t is the length of the tangent drawn from O to the circle. The ratio OB/OA is therefore constant and B is a fixed point. Further, $BP'/AQ = OB/OA = \text{constant}$ and so BP' is constant in length. The inverse of the circle with centre A and radius a is thus a circle with centre B and radius $k^2 a/t^2$.

If the circle passes through the centre of inversion, the above argument breaks down because the points O and Q coincide. In that case, let D be the point which is diametrically opposite to O and D' its inverse (Fig. 25). Then the triangles OPD , $OD'P'$ are similar and the angle $OD'P'$ is a right angle. The locus of P' is thus the straight line through D' which is perpendicular to the diameter through O .

The Reciprocal Transformation : the Point at Infinity. Consider the conformal transformation given by the reciprocal relation

$$w = 1/z.$$

Instead of regarding corresponding values of z and w as being represented by points in different planes, it is convenient to think of the w -plane as superposed upon the z -plane. The numbers z and $1/z$ will then be represented by points P, Q respectively, in the same plane.

From the previous section, it follows that, if P' is the inverse of P in the unit circle with its centre at the origin, then Q is the image of P' in the real axis. Obviously, if P is outside the circle then Q is inside.

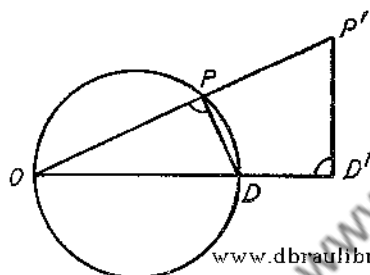

FIG. 25

The relation $w = 1/z$ thus establishes a one-to-one correspondence between points inside the circle, with the exception of the origin, and points outside the circle. If z becomes zero, w becomes infinite. Since, to every point within the circle, other than the origin O , there corresponds

one and only one point outside, we assume that the same is true for the point O and that there is one point—the point at infinity—to which O corresponds.

Thus, in the theory of functions, which makes use of the idea of inversion with respect to a circle, we have only one point at infinity in the z -plane and not a straight line at infinity as in projective geometry.

When it is desired to discuss the behaviour at infinity of a function $f(z)$, we apply the reciprocal transformation and consider the behaviour at the origin of the function $f(1/w)$.

For instance, if $f(z) = a + bz$, where a, b are constants, $f(1/w) = a + (b/w)$ and the latter function has a pole of the first order at $w = 0$. It is said, then, that $f(z)$ has a pole of the first order at infinity.

The Bilinear Transformation. A relation of the form

$$Awz + Bw + Cz + D = 0 \quad . \quad . \quad . \quad (I)$$

in which A, B, C, D are constants (generally complex) such

that $AD \neq BC$, is said to be *bilinear*. To one value of one of the variables w or z there corresponds one and only one value of the other. If $AD = BC$, the relation is of no interest as it would give $z = -B/A$ or else $w = -C/A$.

Such a relation establishes a conformal transformation from

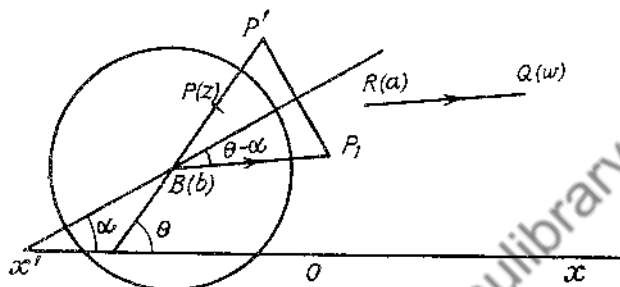

FIG. 26

the z -plane to the w -plane and vice versa. We shall think of the two planes as being superposed.

Solving for w , we have

$$\begin{aligned} w &= -(Cz + D) / (Az + B) \\ &= -(C/A) + \{(BC - AD) / [A(Az + B)]\} \quad (2) \end{aligned}$$

a result which can be expressed in the form

$$w - a = k / (z - b),$$

where a, b, k are constants.

Writing $z - b = re^{i\theta}$ and $k = c^2 e^{2i\alpha}$, we have

$$|w - a| = c^2 / r$$

and, if

$$\phi = \arg(w - a),$$

$$\phi = 2\alpha - \theta,$$

which can be written $\phi - \alpha = \alpha - \theta$.

We can now construct geometrically the point representing w when the point z is given.

Draw a circle of radius c with centre B which represents $z = b$ (Fig. 26). Let P be the point z and P' its inverse with respect to the circle; then, if z' is the affix of P' ,

$$|z' - b| = c^2 / r \text{ and } \arg(z' - b) = \arg(z - b) = \theta.$$

Draw a line through B making an angle α with the real axis and let P_1 be the image of P' in this line. Then the vector $\overline{BP_1}$ represents the complex number of which the modulus is c^2/r and the argument is $2\alpha - \theta$, i.e. the number $w - a$. If, therefore, we draw through the point R (of affix a) the vector \overline{RQ} which is equal to $\overline{BP_1}$ in magnitude and direction, the point Q represents w .

The bilinear transformation is therefore equivalent to an inversion, a reflexion, and a translation.

Since the inverse of a circle is a circle or a straight line, and reflexion and translation do not alter the shape of a figure, circles are transformed into circles or straight lines.

Suppose that, by the bilinear relation, the points z_1, z_2, z_3, z_4 are transformed into the points w_1, w_2, w_3, w_4 , respectively, all the eight points being at a finite distance from the origin. Using equation (2), p. 85, we have

$$w_1 - w_3 = - (BC - AD) (z_1 - z_3) / (Az_1 + B) (Az_3 + B)$$

along with similar expressions for the differences $w_1 - w_4$, etc.

$$\begin{aligned} \text{Hence} \quad & [(w_1 - w_3)/(w_2 - w_3)] : [(w_1 - w_4)/(w_2 - w_4)] \\ & = [(z_1 - z_3)/(z_2 - z_3)] : [(z_1 - z_4)/(z_2 - z_4)], \end{aligned}$$

$$\text{or} \quad (w_1 w_2 w_3 w_4) = (z_1 z_2 z_3 z_4)$$

where $(z_1 z_2 z_3 z_4)$ stands for the expression on the right-hand side of the above equation. This expression is known as the *generalized cross-ratio* of the four points z_1, z_2, z_3, z_4 . *The cross-ratio is thus left unaltered by any bilinear transformation.*

Further, it follows that the bilinear transformation which converts three given points z_1, z_2, z_3 into w_1, w_2, w_3 , respectively, can be expressed in the form

$$(zz_1 z_2 z_3) = (ww_1 w_2 w_3).$$

This transformation converts the circle which passes through z_1, z_2, z_3 into the circle through w_1, w_2, w_3 .

It follows that a bilinear transformation can always be found so as to transform any given circle in the z -plane into a given circle in the w -plane; for we can use the above transformation taking z_1, z_2, z_3 to be points on the first circle and w_1, w_2, w_3 to be points on the second.

Similarly any given straight line in the z -plane may be transformed into any given straight line in the w -plane. In particular, the real axis of z may be transformed into the real axis of w by giving real values to $z_1, z_2, z_3, w_1, w_2, w_3$.

THE DOUBLE POINTS. If corresponding values of z and w are represented by points in the same plane, these points are, in general, distinct, but they coincide if z satisfies the quadratic

$$Az^2 + (B + C)z + D = 0,$$

which is obtained from the equation of transformation by putting w equal to z . Thus there are, in general, two distinct points which are the *self-corresponding* or *double points*. There are two cases to be considered.

Case i. Suppose that the above quadratic has two distinct roots α, β .

$$\text{Since } w = -(Cz + D)/(Az + B)$$

$$\text{and } \alpha = -(C\alpha + D)/(A\alpha + B),$$

$$w - \alpha = (AD - BC)(z - \alpha)/[(A\alpha + B)(Az + B)];$$

similarly

$$w - \beta = (AD - BC)(z - \beta)/[(A\beta + B)(Az + B)].$$

By division, we have

$$(w - \alpha)/(w - \beta) = K(z - \alpha)/(z - \beta),$$

$$\text{where } K = (A\beta + B)/(A\alpha + B).$$

$$\text{Hence, } |(w - \alpha)/(w - \beta)| = |K| \cdot |(z - \alpha)/(z - \beta)| \quad (3)$$

$$\text{and } \arg(w - \alpha) - \arg(w - \beta) = \arg K + \arg(z - \alpha) - \arg(z - \beta) + 2n\pi \quad (4)$$

where n is zero or an integer.

If z moves so that $|(z - \alpha)/(z - \beta)|$ is constant, its locus is a circle of the coaxial system which has the double points α and β as limiting points, and equation (3) shows that the locus of w is a circle of the same system. Again, if z moves so that $\arg(z - \alpha) - \arg(z - \beta)$ is constant, its locus is a circle of the coaxial system which passes through the double points α and β . From equation (4) it is seen that the locus of w is a circle of the same system (see Examples 12 and 13 on pp. 13-14).

Case ii. If $(B + C)^2 = 4AD$, the double points coincide at the point $z = \alpha$, where $\alpha = -(B + C)/2A$. In this case, the transformation is said to be *parabolic*.

Since $A\alpha + B = \frac{1}{2}(B - C)$ and $AD - BC = \frac{1}{2}(B - C)^2$, the relation

$$w - \alpha = (AD - BC)(z - \alpha) / [(A\alpha + B)(Az + B)]$$

reduces to

$$1/(w - \alpha) = [1/(z - \alpha)] + [2A/(B - C)].$$

EXAMPLE 4. Apply the transformation $w = (iz + 1)/(z + i)$ to the areas in the z -plane which are respectively inside and outside the unit circle with its centre at the origin.

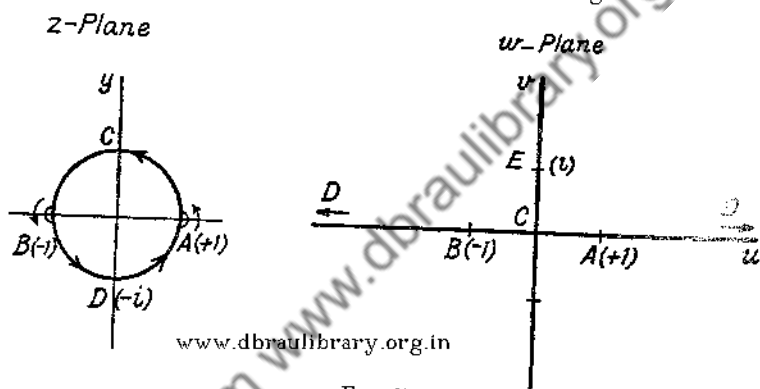

FIG. 27

The self-corresponding points A, B are given by

$$z = (iz + 1)/(z + i),$$

$$z = \pm 1.$$

i.e.

Since

$$w - 1 = (i - 1)(z - 1)/(z + i)$$

and

$$w + 1 = (i + 1)(z + 1)/(z + i),$$

we have $(w - 1)/(w + 1) = i(z - 1)/(z + 1)$.

Hence, in general, a circle which passes through the points A, B , at which $z = \pm 1$, is transformed into a circle through the points $w = \pm 1$ in the w -plane. In particular, the latter circle may degenerate into a straight line.

In Fig. 27, the z - and w -planes are shown separately and corresponding points are indicated by the same letter.

It is at once obvious from the equation of transformation that w is finite for all values of z except $-i$. Hence the point $D(z = -i)$ corresponds to the point at infinity in the w -plane.

Since $dw/dz = -2/(z+i)^2$, the magnification is finite and not zero at all points except D and the point at infinity in the z -plane (the latter point corresponds to the point E at which $w = i$). Thus it is only at D and E that the transformation is not conformal.

When z describes the circle $|z| = 1$ in the positive sense with respect to its interior, both $\arg(z-1)$ and $\arg(z+1)$ vary continuously except when z passes through the points A, B at which $z = \pm 1$. In order to see what happens at these points we shall make the point z avoid actually passing through the points of discontinuity by letting it describe circular arcs of vanishingly small radius about A and B . When transforming the exterior area we shall take these arcs to be outside the circle as shown in the figure.

While z describes the arc about A , the angle between the vector $z-1$ and the real axis varies continuously between values which are nearly equal to $-\pi/2$ and $+\pi/2$. If the radius of the arc is diminished to zero, the amount of the discontinuity is π . Similarly, when z makes the detour round B , the angle between the vector $z+1$ and the real axis varies continuously between values which are ultimately $\pi/2$ and $3\pi/2$.

Let the point z start from D and move, in the counter-clockwise sense, round the circle $z = 1$, making detours round the points A and B . When z is on the quadrant DA , we can take

$$\arg [(z-1)/(z+1)] = -\pi/2$$

and therefore $\arg [(w-1)/(w+1)] = \arg i - \pi/2 = 0$.

The corresponding point w is then on the positive part of the real axis and moves from infinity to A ($w = 1$) as z moves from D to A .

When z makes the small detour round A , $\arg [(z-1)/(z+1)]$ changes from $-\pi/2$ to $+\pi/2$ and so $\arg [(w-1)/(w+1)]$ increases from 0 to π . As z describes the semicircle ACB , $\arg [(z-1)/(z+1)]$ is constant and equal to $\pi/2$: the corresponding point w moves from A to B along the real axis. As z moves round B , $\arg [(w-1)/(w+1)]$ decreases from π to 0 and it retains the latter value while z moves along the quadrant BD . The corresponding point w therefore moves along the real axis from B to infinity.

Thus, as z describes the circle in the sense $DAACBD$, w moves in the negative direction along the whole of the real axis in

the w -plane. The area outside the circle in the z -plane is on the right of an observer who moves in the sense $DACBD$ and so the corresponding area in the w -plane bears the same relation to an observer who describes the corresponding path. Thus the upper half of the w -plane corresponds to the exterior and the lower half to the interior of the circle.

EXAMPLE 5. Express the relation $w = (13iz + 75)/(3z - 5i)$ in the form $(w - a)/(w - b) = k(z - a)/(z - b)$, where a, b, k are constants.

Show that the circle in the z -plane whose centre is $z = 0$ and whose radius is 5, is transformed into the circle in the

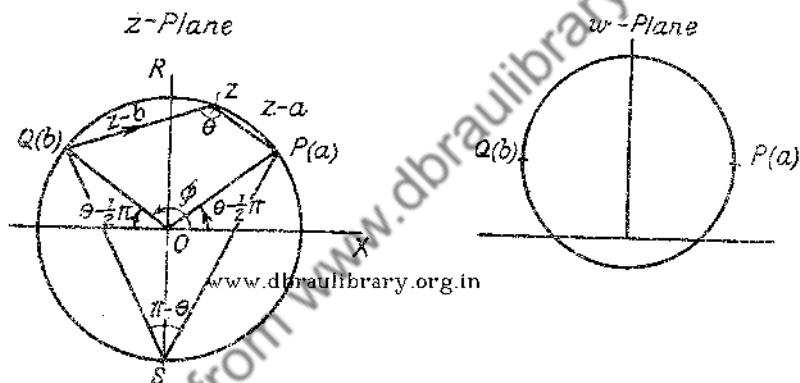

FIG. 28

w -plane on the line joining the points $w = a$ and $w = b$ as diameter, and that points in the z -plane which are exterior to the former circle are transformed into points in the w -plane within the latter circle.

The self-corresponding points are given by the quadratic

$$z(3z - 5i) = 13iz + 75, \text{ i.e. } (z - 3i)^2 = 16,$$

the roots of which are $a = 4 + 3i$ and $b = -4 + 3i$.

$$\text{Since } a = (13ia + 75)/(3a - 5i)$$

$$\begin{aligned} w - a &= [(13iz + 75)/(3z - 5i)] - [(13ia + 75)/(3a - 5i)] \\ &= -160(z - a)/(3a - 5i)(3z - 5i). \end{aligned}$$

Similarly

$$w - b = -160(z - b)/(3b - 5i)(3z - 5i)$$

and therefore

$$\begin{aligned}(w-a)/(w-b) &= [(3b-5i)/(3a-5i)] [(z-a)/(z-b)] \\ &= [(-4+3i)/5] [(z-a)/(z-b)].\end{aligned}$$

The points $z = a$, $z = b$ lie on the circle $|z| = 5$ and it follows immediately that this circle is transformed into a circle in the w -plane passing through the points $w = a$, $w = b$.

When z lies on the minor arc PRQ (Fig. 28) of the circle $|z| = 5$, where P , Q are the points $z = a$, $z = b$,

$$\arg(z-a) - \arg(z-b) = \theta = \angle PRQ$$

and

$$\arg[(-4+3i)/5] = \arg b = \phi = \angle XOQ.$$

Hence $\arg(w-a) - \arg(w-b) = \angle XOQ + \angle PRQ = 3\pi/2$.

When z lies on the major arc PSQ ,

$$\arg(z-a) - \arg(z-b) = \theta - \pi$$

and

$$\arg(w-a) - \arg(w-b) = \pi/2.$$

As z describes the circle $|z| = 5$, it follows that w describes the circle on ab as diameter in the w -plane, the upper half of this circle corresponding to the major arc PSQ . The point $z = 0$ corresponds to the point $w = 1/5$, and this is obviously outside the w -circle, the interior of which must therefore correspond to the exterior of the z -circle.

The Transformation $w = z + (k^2/z)$. where k is real and positive. This transformation finds many applications, particularly in hydrodynamics in connection with two-dimensional flow past a flat plate, a circular or elliptic cylinder, and an aerofoil.

Since $dw/dz = 1 - (k^2/z^2)$, which is finite at all points except $z = 0$ and not zero except at $z = \pm k$, the transformation is conformal at all points other than these. As z approaches infinity, w approaches equality with z and the magnification $|dw/dz|$ approaches unity. Hence an area at a great distance from the origin in the z -plane is transformed into an almost identical area at a great distance from the origin in the w -plane.

Consider (Fig. 29) the transformation of the circle $|z| = c$, where $c > k$. At any point on this circle we have $z = ce^{i\theta}$, and therefore

$$\begin{aligned}w = u + iv &= ce^{i\theta} + (k^2/c)e^{-i\theta} \\ &= a \cos \theta + ib \sin \theta,\end{aligned}$$

where $a = (c^2 + k^2)/c$ and $b = (c^2 - k^2)/c$.

Hence $u = a \cos \theta$ and $v = b \sin \theta$.

As θ increases from $-\pi$ to $+\pi$, the point z describes the circle once in the counter-clockwise direction and the point w moves once in the same sense round the ellipse

$$(u/a)^2 + (v/b)^2 = 1.$$

The area outside the circle is transformed into the area outside the ellipse.

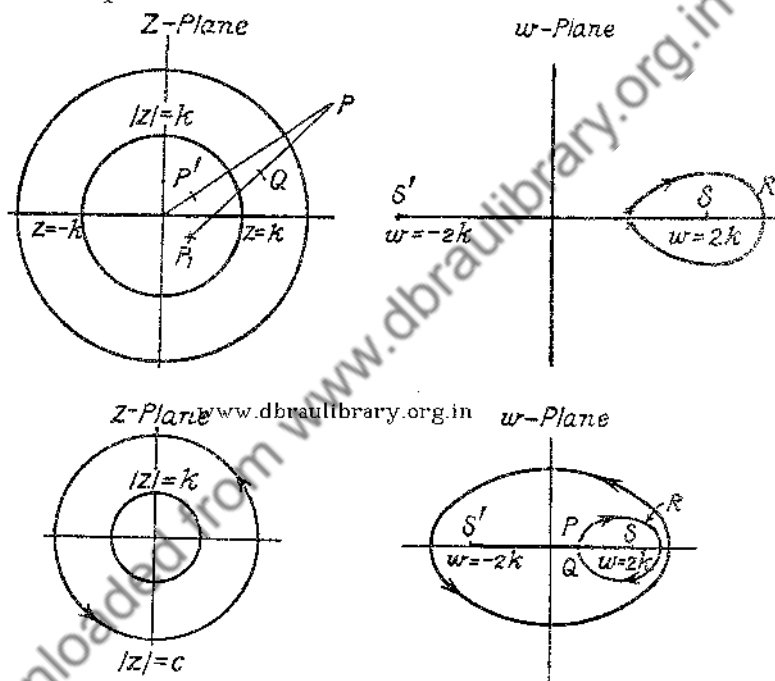

FIG. 29

The foci S , S' of the ellipse are given by

$$w = \pm(a^2 - b^2)^{\frac{1}{2}} = \pm 2k,$$

and the corresponding points in the z -plane are $z = \pm k$.

If c is made equal to k , the major axis $2a$ of the ellipse becomes equal to $4k$ and the minor axis $2b$ vanishes. The ellipse then degenerates into the line SS' . A point z , which moves in the trigonometrically positive sense round the circle, is transformed into a point in the w -plane which moves along the real axis

from S' to S and then back from S to S' . The area outside the circle in the z -plane becomes the area of the whole w -plane with an internal boundary SS' which may be regarded as an impassable barrier (as in hydrodynamics) or as a slit in the plane. In either case, a point which moves in the plane must avoid crossing the barrier or slit. For instance, in order to move from a position P on the upper edge of the slit to the opposite point Q on the lower edge, the point would have to describe a path like PRQ surrounding either S or S' .

To a given point in the z -plane corresponds one and only one point in the w -plane, but, to one point in the latter plane, there correspond in general two points in the z -plane which are given by the roots of the quadratic equation

$$z^2 - wz + k^2 = 0.$$

The product of the roots of this equation being k^2 , it follows that one of the points is inside and the other outside the circle $|z| = k$, unless the given value of w is represented by a point on one of the edges of the slit, in which case both points are on the circle. There is thus a one-to-one correspondence between points in the w -plane, slit along the real axis between S and S' , and points outside the circle in the z -plane.

A CONSTRUCTION FOR CORRESPONDING POINTS. If P is any point in the z -plane, let P' be its inverse with respect to the circle $|z| = k$, and P_1 the image of P' in the real axis. Then if z is the affix of P , the affix of P_1 is k^2/z (see p. 83). If Q is the middle point of PP_1 , its affix is $\frac{1}{2}[z + (k^2/z)] = \frac{1}{2}w$.

This gives a simple construction for the curve in the w -plane which corresponds to any given curve in the z -plane. If the latter curve is drawn to a scale of twice full size, the locus of Q , which may be readily traced, will be the actual curve which is required.

Transformation of a Circle into a Circular Arc. Apply the transformation to any circle which passes through the two points $z = \pm k$. If z is any point on such a circle, we can take

$$\arg [(z - k)/(z + k)] = \alpha \text{ or } \alpha - \pi,$$

where α is constant, according as z is above or below the real axis. If z moves round the circle in the counter-clockwise sense, $\arg [(z - k)/(z + k)]$ changes from $\alpha - \pi$ to α when the point passes through k and from α to $\alpha - \pi$ when it passes through $-k$.

Now since $w - 2k = (z - k)^2/z$
 and $w + 2k = (z + k)^2/z$,
 $(w - 2k)/(w + 2k) = [(z - k)/(z + k)]^2$,
 whence

$$\begin{aligned}\arg(w - 2k) - \arg(w + 2k) &= 2[\arg(z - k) - \arg(z + k)] \\ &= 2\alpha \text{ or } 2\alpha - 2\pi,\end{aligned}$$

according as z is above or below the real axis.

Hence, as z describes the circle, starting at the point k , the locus of the point w , in the w -plane, is an arc of a circle joining the points $w = \pm 2k$, the angle subtended by these two points at any point of the arc being 2α . As z moves from k to $-k$ along the upper arc, the point w moves from $2k$ to $-2k$. When z passes through the point $-k$, $\arg[(z - k)/(z + k)]$ changes from α to $\alpha - \pi$ while $\arg[(w - 2k)/(w + 2k)]$ changes from 2α to $2\alpha - 2\pi$ and retains this value as w returns to the point $2k$. The arc in the w -plane is thus described twice.

The area outside the circle in the z -plane is transformed into the whole w -plane bounded internally by the circular arc.

THE AEROFOIL. Any circle in the z -plane which passes through the point $z = k$ and contains within it the point $z = -k$ is transformed into a closed curve in the w -plane which passes through the point $w = 2k$. As the point z moves along the circumference through the point k , $\arg(z - k)$ changes suddenly by an amount π while $\arg(z + k)$ varies continuously. It follows that there is a discontinuity of amount 2π in the value of $\arg[(w - 2k)/(w + 2k)]$ when w moves along the curve in the w -plane through the point $2k$ and so this curve must have a cusp at that point.

By choosing a suitable centre and radius for the circle, the corresponding curve in the w -plane may be made to give a close approximation to the section of an aeroplane wing; a cylinder which has such a curve as its cross-section is called a *Joukowski aerofoil*.

The Transformation $w = \log z$. If we assume the logarithm to have its principal value,

$$w = u + iv = \log_e r + i\theta,$$

where r is the modulus and θ the principal argument of z .

If z starts at the point $-a$ and describes the circle $|z| = a$ once in the counter-clockwise sense, u is constant and v varies

continuously from $-\pi$ to π . If z continued its motion there would be a discontinuity in θ when it crossed the real axis at $-a$. To avoid this, we can imagine the plane slit along the whole of the negative part of the real axis.

Since $dw/dz = 1/z$, the only singular points are the origin and the point at infinity. In the portion of the cut plane which lies between the circles $|z| = a$, $|z| = b$ ($b < a$), the principal value of $\log z$ is one-valued, finite and continuous.

Suppose (Fig. 30) that the point z moves round the boundary consisting of the circle $ABCDE$ ($|z| = a$), the upper edge EF

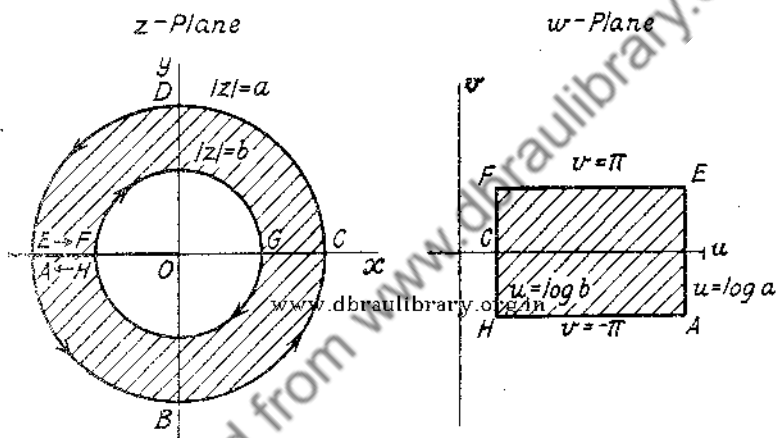

FIG. 30

of the cut, the circle FGH ($|z| = b$), and the lower edge HA of the cut, the direction of motion being indicated by the order of mention of the letters.

As z describes $ABCDE$, w moves along the line $u = \log a$ between the points at which v has the values $-\pi$ and $+\pi$. When z moves from E to F , v is constant and equal to π , while u decreases from $\log a$ to $\log b$. As z moves round FGH , w moves along the line $u = \log b$ between the points at which $v = \pm \pi$. Finally, as z returns to A along HA , v is constant at the value $-\pi$ and u increases from $\log b$ to $\log a$.

Thus the rectangle $AEFH$ in the w -plane, with its sides along the lines $u = \log a$, $v = \pi$, $u = \log b$, $v = -\pi$, corresponds to the boundary in the z -plane and the area within either boundary is represented conformally on the other.

If a is increased without limit and b is diminished to zero, the rectangle in the w -plane becomes the doubly infinite strip between the lines $v = \pm \pi$, and this corresponds to the whole of the cut z -plane.

The Transformation $w = \cosh z$. Here

$$u + iv = \cosh x \cos y + i \sinh x \sin y$$

and

$$u = \cosh x \cos y, \quad v = \sinh x \sin y.$$

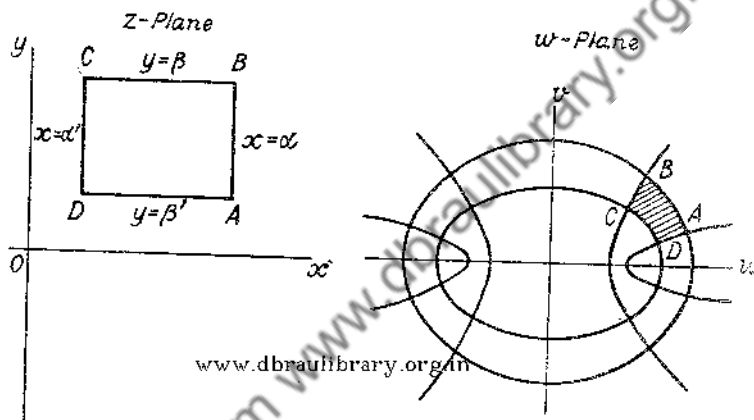

FIG. 31

If x is constant, the locus of the point w is the ellipse

$$u^2/\cosh^2 x + v^2/\sinh^2 x = 1;$$

if y is constant, the locus of w is the hyperbola

$$u^2/\cos^2 y - v^2/\sin^2 y = 1.$$

Clearly the two curves are confocal, the common foci being at the points $w = \pm 1$.

The rectangle $ABCD$ (Fig. 31) in the z -plane, with sides along the lines $x = \alpha$, $y = \beta$, $x = \alpha'$, $y = \beta'$, is transformed into the area $ABCD$ in the w -plane between the corresponding ellipses and hyperbolas. Actually there are four such areas but only one of these corresponds to the rectangle $ABCD$: the others are obtained from the areas which are the images of $ABCD$ in the x - and y -axes.

The Transformation $z = c \tan \frac{1}{2}w$. Taking c to be real (and positive), we have

$$x + iy = c \tan \frac{1}{2}(u + iv), \quad x - iy = c \tan \frac{1}{2}(u - iv)$$

$$\text{and so } \tan u = \tan \left[\frac{1}{2}(u + iv) + \frac{1}{2}(u - iv) \right] \\ = 2cx / (c^2 - x^2 - y^2) \quad \dots \quad (5)$$

$$\text{and } \tan iv = \tan \left[\frac{1}{2}(u + iv) - \frac{1}{2}(u - iv) \right] \\ = 2icy / (c^2 + x^2 + y^2) \quad \dots \quad (6)$$

From (5) and (6) it follows that the lines $u = \text{constant}$ and $v = \text{constant}$ in the w -plane correspond to the families of coaxial circles in the z -plane given by the equations

$$x^2 + y^2 + 2xc \cot u - c^2 = 0 \quad \dots \quad (7)$$

$$\text{and } x^2 + y^2 - 2yc \coth v + c^2 = 0 \quad \dots \quad (8)$$

The circle $u = \text{constant}$ passes through the points $A(0, c)$ and $B(0, -c)$. Its centre is at $(-c \cot u, 0)$ and its radius is $\pm c \operatorname{cosec} u$ according as u is positive or negative.

The circle $v = \text{constant}$ has its centre at $(0, c \coth v)$ and its radius is $\pm c \operatorname{cosech} v$ according as v is positive or negative. When v is $\pm \infty$, the radius is zero and the centre is at $(0, \pm c)$; i.e. the points A and B are the limiting points of the v -system.

Let P (Fig. 32) be the point which represents z , then the vectors \overline{AP} , \overline{PB} represent $z - ic$, $-z - ic$, respectively.

Now

$$(z - ic) / (-z - ic) = (iz + c) / (-iz + c) \\ = (\cos \frac{1}{2}w + i \sin \frac{1}{2}w) / (\cos \frac{1}{2}w - i \sin \frac{1}{2}w) \\ = \exp(iw) \\ = \exp(-v + iu).$$

$$\text{Hence } AP/PB = |(z - ic) / (-z - ic)| \\ = \exp(-v),$$

and one determination of $\arg [(z - ic) / (-z - ic)]$ is equal to u .

Now, when P is to the right of the imaginary axis, one determination of $\arg [(z - ic) / (-z - ic)]$ is

$$XQP + XRB = \pi - APB,$$

where XQP , etc., denote the positive measures (between 0 and π) of the angles.

When P is on the left of the imaginary axis one value of $\arg [(z - ic)/(-z - ic)]$ is

$$\begin{aligned} XQ'P - (2\pi - XR'B) &= -R'Q'P - Q'R'P \\ &= APB - \pi. \end{aligned}$$

As P moves about in the right-hand half of the z -plane, the angle APB varies from 0 (on AY and BY') to π (on AB). The corresponding value of $\arg [(z - ic)/(-z - ic)]$ ranges from π to 0.

When P moves in the left-hand half of the plane, APB

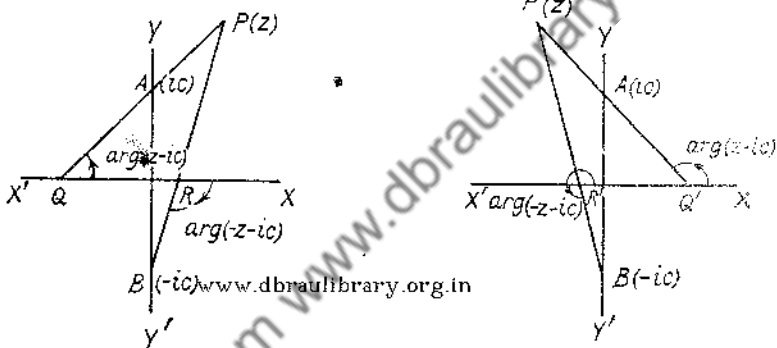

FIG. 32

again varies from 0 to π and the above argument varies from $-\pi$ (when P is on AY or BY') to 0 (when P is on AB).

Hence if P is on the right of the imaginary axis we shall take u to lie between 0 and π , while, if P is on the left of the axis, we shall take u to lie between $-\pi$ and 0. If P crosses the axis between the points A and B , u varies continuously, but, if P crosses outside the segment AB , u is discontinuous. The discontinuity may be removed by slitting the plane along the whole of the y -axis outside the segment AB .

Since $v = \log(PB/AP)$, the values of v range from $-\infty$ (when P is at B) to $+\infty$ (when P is at A). The line $v = 0$ corresponds to the real axis. The whole of the z -plane is thus represented on the doubly-infinite strip of the w -plane bounded by the lines $u = \pm \pi$.

That part of the z -plane which is outside the circles $v = a (> 0)$ and $v = b (< 0)$ corresponds to the interior of the rectangle in

the w -plane bounded by the lines $u = \pm \pi$, $v = a$, $v = b$. (See Fig. 33, in which corresponding points in the two planes are denoted by the same letter.)

This transformation is used in dealing with two-dimensional potential problems involving circular cylinders with parallel axes.

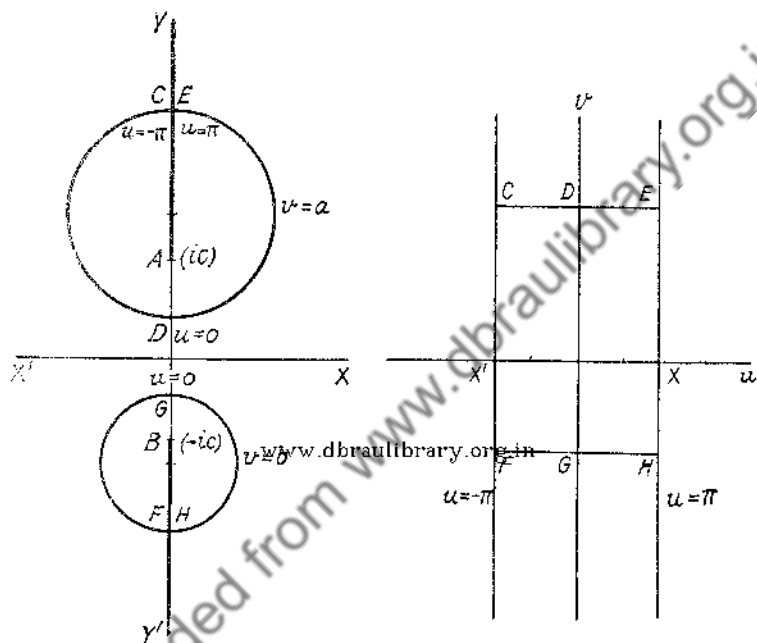

FIG. 33

Successive Transformations. By means of a relation of the form

$$Z = f(z)$$

we may transform conformally a figure in the z -plane into a figure in the Z -plane, and this again may be transformed conformally on to the w -plane by a relation

$$w = F(Z).$$

Clearly the figure so obtained in the w -plane could have been obtained by the direct transformation given by

$$w = F(f(z)).$$

In practice, it is sometimes convenient to treat a fairly complicated transformation as the resultant of two or more simpler transformations applied successively.

EXAMPLE 6. Consider the effect of applying the transformation

$$w = \log \coth \frac{1}{2}z$$

to the semi-infinite strip on the positive side of the imaginary axis between the lines $y = \pm \pi$.

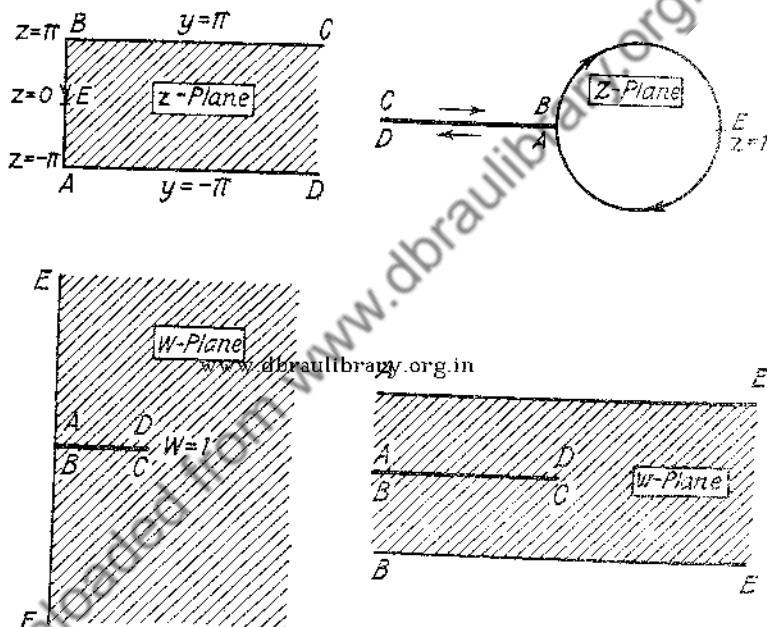

FIG. 34

The given relation is equivalent to the successive substitutions

$$(i) Z = e^z, (ii) W = (Z + 1)/(Z - 1), (iii) w = \log W,$$

where $Z = X + iY$, $W = U + iV$.

In Fig. 34, let z start at infinity on CB and move round the boundary $CBAD$ of the given strip. Here C and D denote points at an infinite distance from the origin—actually they are the same point, since, from the point of view of the

theory of functions, there is only one point at infinity in the complex plane.

When z is on CB , $Z = \exp(x + i\pi) = -\exp(x)$ and so Z increases from $-\infty$ to -1 . When z moves along BA , $Z = \exp(iy)$ and the point Z describes (in the clockwise direction) the unit circle with centre at the origin from the point $B(Z = -1)$ to the point A (where Z has the same value as at B). As z moves from A to D , $Z = \exp(x - i\pi) = -\exp(x)$ decreases from -1 to $-\infty$.

Apparently the lines BC , AD in the z -plane are transformed into the same line, but, if we cut the Z -plane along the real axis from -1 to $-\infty$, we can regard the upper and lower edges of the cut as the lines which correspond to BC and AD respectively.

The interior of the strip is now represented on the area outside the circle in the cut Z -plane. To this area we now apply the bilinear transformation (ii).

As Z moves along CB , W is real and decreases from 1 (when Z is infinite) to 0 at B , where $Z = -1$. When Z moves on the upper half of the circle from B to E , $\arg W$ is constant and equal to $-\pi/2$ while W varies from zero at B to an infinite value at E . Thus the lower half of the imaginary axis in the W -plane corresponds to the upper semicircle in the Z -plane.

When Z is on the lower half of the circle, $\arg W = \pi/2$ and W varies from an infinite value at E to zero at A ; therefore the point W moves down the imaginary axis to the point A (where $W = 0$). Along AD , W is real and varies from 0 at A to 1 at D .

The area obtained in the W -plane is that to the right of the imaginary axis with a slit along the real axis between the points $W = 0$, $W = 1$. This area is now transformed by (iii) in which we shall give the logarithm its principal value.

We have $w = u + iv = \log R + i\phi$, where $R = |W|$ and ϕ is the principal value of $\arg W$. On EA , $v = \phi = \pi/2$ and $u (= \log R)$ varies from $+\infty$ at E to $-\infty$ at A ; on BE , $\phi = -\pi/2$ and u varies from $-\infty$ at B to $+\infty$ at E . On AD , $v = \phi = 0$ and u varies from $-\infty$ at A to zero at D ; on CB , $v = \phi = 0$ and u varies from 0 at C to $-\infty$ at B .

The corresponding area in the w -plane is thus the doubly infinite strip between the lines $v = \pm \pi/2$, there being a cut along the whole of the negative part of the real axis.

Conformal Mapping of a Spherical Surface on a Plane. Let SN (Fig. 35) be a fixed diameter of a sphere of radius a and

centre O . Draw through S a pair of tangents SX, SY such that $\angle XSY$ is a right angle.

The position of a variable point P on the surface of the sphere is clearly determined by the angle ϕ between the planes PSN, XSN and the angle θ between OS and OP . These two angles may be called the spherical co-ordinates of P . The angle ϕ , which is the longitude of P , will be measured positively in the sense of rotation from SX to SY and may be taken to

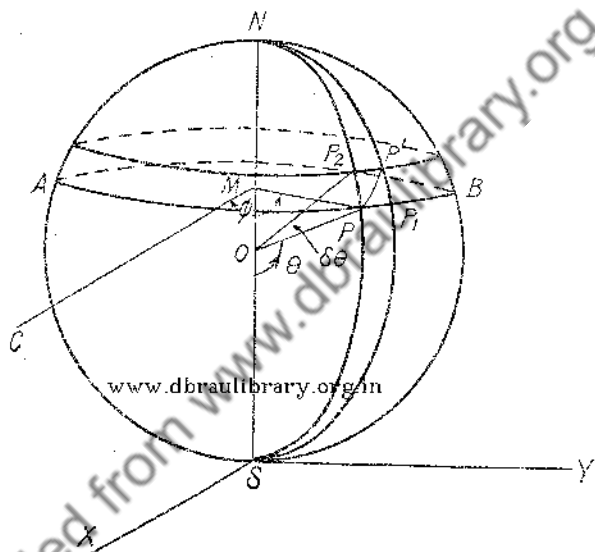

FIG. 35

range from $-\pi$ to $+\pi$. The angle θ , which is simply related to the latitude of P , ranges from 0 to π .

If θ is kept constant and ϕ varies from $-\pi$ to $+\pi$, P describes a small circle APB on the sphere (a parallel of latitude) with radius $a \sin \theta$ and centre M , which is the foot of the perpendicular from P to SN . If ϕ is constant and θ varies from 0 to π , P moves from S to N along a great semicircle SPN , called the meridian of P . Since the planes APB, SPN are perpendicular, the arcs PB, PN intersect at right angles at P .

Let P and P' be neighbouring points on a curve drawn on the surface, the spherical co-ordinates of P' being $(\phi + \delta\phi, \theta + \delta\theta)$. Then the meridian of P' meets the parallel of latitude through

P in P_1 , such that the arc $PP_1 = a \sin \theta \cdot \delta\phi$, and the parallel of latitude through P' meets the meridian of P in P_2 such that the arc $PP_2 = a\delta\theta$.

We have thus constructed an element $PP_1P'P_2$ of the surface of the sphere, all four angles of the element being right angles. If θ and ϕ are sufficiently small, we may treat the bounding arcs as straight lines, and take the area of the element to be $a^2 \sin \theta \cdot \delta\phi\delta\theta$.

The element of length δs on the surface is the length PP' which is given by

$$PP'^2 = PP_1^2 + PP_2^2,$$

whence
$$\delta s^2 = (a^2 \sin^2 \theta) (\delta\phi^2 + \operatorname{cosec}^2 \theta \cdot \delta\theta^2).$$

If we put $\psi = \log \tan \frac{1}{2}\theta$, we have

$$\delta\psi = \operatorname{cosec} \theta \cdot \delta\theta \text{ and } \sin \theta = \operatorname{sech} \psi,$$

from which it follows that

$$\delta s^2 = (a^2 \operatorname{sech}^2 \psi) (\delta\phi^2 + \delta\psi^2)$$

and that

$$\begin{aligned} \tan P_1PP' &= P_1P'/PP_1 \\ &= \delta\psi/(\sin \theta \cdot \delta\phi) \\ &= \delta\psi/\delta\phi. \end{aligned}$$

If P'' , with spherical co-ordinates $(\phi + \Delta\phi, \theta + \Delta\theta)$, is another point close to P and the arc $PP'' = \Delta s$, we have, in a similar way,

$$\Delta s^2 = (a^2 \operatorname{sech}^2 \psi) (\Delta\phi^2 + \Delta\psi^2)$$

and $\tan P_1PP'' = \Delta\psi/\Delta\phi$, where $\Delta\psi = \operatorname{cosec} \theta \cdot \Delta\theta$.

Now take ϕ and ψ to be the rectangular cartesian co-ordinates of a point in a plane and plot the points Q, Q', Q'' with co-ordinates $(\phi, \psi), (\phi + \delta\phi, \psi + \delta\psi), (\phi + \Delta\phi, \psi + \Delta\psi)$, respectively. Then

$$QQ'^2 = \delta\phi^2 + \delta\psi^2, \quad QQ''^2 = \Delta\phi^2 + \Delta\psi^2$$

and the gradients of the straight lines QQ', QQ'' are $\delta\psi/\delta\phi, \Delta\psi/\Delta\phi$, respectively.

Hence $QQ'/QQ'' = \delta s/\Delta s = PP'/PP''$

and the angles $Q'QQ'', P'PP''$ are equal.

The elementary triangles $QQ'Q'', PP'P''$ are therefore similar and the spherical surface is represented conformally on the ϕ, ψ -plane.

The meridians on the sphere become the straight lines $\phi = \text{constant}$ on the plane, the values of the constant ranging from $-\pi$ to $+\pi$; the parallels of latitude ($\theta = \text{constant}$) on the sphere become the straight lines $\psi = \text{constant}$ in the plane. As θ varies from 0 to π , $\psi (= \log \tan \frac{1}{2}\theta)$ varies from $-\infty$ to $+\infty$.

Thus the whole surface of the sphere is represented conformally on the doubly-infinite strip between the lines $\phi = \pm \pi$. The map so obtained is called *Mercator's Projection*.

It will be noticed that any two curves which intersect on the sphere at an angle α are represented by plane curves intersecting at an angle α . In particular, since any straight line in the plane map cuts all the meridian lines at the same angle, the curve on the sphere, which corresponds to the straight line, cuts all the meridians at the same angle. Such a curve is called a *rumb line* or *loxodrome*.

Having constructed one conformal map, we can now derive an unlimited number. For the figure in the ϕ, ψ -plane may be represented conformally on the plane of the complex variable z by an infinite number of relations of the type

$$z = f(\phi + i\psi).$$

Taking

$$w = \frac{z - 2i}{z + 2i} = \frac{\phi + i\psi - 2i}{\phi + i\psi + 2i},$$

we obtain the *stereographic projection* in which the meridians are the lines $\arg z = \text{constant}$ and the parallels of latitude are the circles $|z| = \text{constant}$.

EXERCISES

1. If $z_0 = 1$ and if the point which represents z describes a circle of radius c with its centre at the point $a + ib$, show that the point w describes a circle of radius $c/(a^2 + b^2 - c^2)$.

If P represents z and Q represents $(1/z) - (3/4) - i$, find the locus of Q when P describes the circle $|z - 2| = 2$.

2. In an Argand diagram the point z moves along the real axis from $z = -1$ to $z = +1$. Find the corresponding motion of the point $(1 - iz)/(z - i)$. (U.L.)

3. Prove that the relation $w = (kz + 1)/(z + k)$, where k is any real number other than ± 1 , transforms the circle $|z| = 1$ into the circle $|w| = 1$. Prove also that, if $z = \exp(i\theta)$ and $\arg(w + 1) = \phi$, then $(k + 1) \tan \phi = (k - 1) \tan \frac{1}{2}\theta$. (U.L.)

4. Show that, in a bilinear transformation $w = (az + b)/(cz + d)$, the ratio $[(z_1 - z_2)/(z_1 - z_3)] : [(z_4 - z_2)/(z_4 - z_3)]$ remains invariant.

Find the form of the transformation T which leaves $z = 1$ and $z = i$ unaltered and transforms $z = -1$ into $w = -i$.

By means of an auxiliary transformation U , which transforms i into 0 and 1 into ∞ , show that by the transformation T any circle through the two points $i, 1$ is transformed into itself. Hence describe the general character of the transformation T . (U.L.)

5. Prove that a bilinear transformation transforms any circle into a circle or a straight line.

Obtain the bilinear transformations which transform the circle

$$\begin{aligned} |z| &= 2 \text{ into itself, the point } 4 \text{ into the origin and the circle} \\ |z| &= 1 \text{ into a line parallel to the imaginary axis.} \end{aligned} \quad (U.L.)$$

6. Prove that the necessary and sufficient condition that four points in the z -plane should be either collinear or concyclic is that their cross-ratio should be real.

7. The bilinear relation $w = f(z) = (Az + B)/(Cz + D)$ is such that

- (i) $w \rightarrow a$ as $z \rightarrow \infty$;
- (ii) $z \rightarrow b$ as $w \rightarrow \infty$;
- (iii) there is only one number c such that $c = f(c)$. Find A, B, C, D in terms of a, b, c and show that $2c = a + b$.

Show that, if z_1 does not lie on the straight line λ joining a and b , then the set of points

$$z_1, z_2 = f(z_1), z_3 = f(z_2), \dots, z_{n+1} = f(z_n)$$

all lie on a circle which touches λ at c . Prove that $z_n \rightarrow c$ as $n \rightarrow \infty$. (U.L.)

8. Prove that the transformation

$$w = [(1 + z^2) - i(1 - z^2)] / [(1 + z^2) + i(1 - z^2)]$$

maps the region $|z| < 1, 0 < \arg z < \pi/3$ conformally on $|w| < 1$. Discuss the correspondence between the boundaries of the two regions. (U.L.)

9. Examine the transformation $2w = z + 1/z$ and discuss its singularities.

Show that $|w| = 1$ corresponds to either

$$|z - i| = \sqrt{2} \text{ or } |z + i| = \sqrt{2}. \quad (U.L.)$$

10. Show that the equation

$$(a - b)w^2 - 2zw + (a + b) = 0, \quad (a > b > 0),$$

represents the interior of the circle $|w| = 1$ on the area in the z -plane outside the ellipse $(x/a)^2 + (y/b)^2 = 1$.

Discuss the representation in the z -plane of the circles

$$|w| = r, |w| = (a + b)/(a - b),$$

and of the line $\arg w = \alpha$.

11. Show that the transformation $w(z + i)^2 = 1$ maps the interior of the circle $|z| = 1$ in the z -plane on the domain outside the parabola $2R(1 - \cos \phi) = 1$ in the w -plane (R, ϕ being polar co-ordinates of a point in this plane).

Show that the same transformation effects two mappings on the z -plane of the domain outside the parabola; the one on the interior of the circle $|z| = 1$ and the other on the interior of the circle $|z + 2i| = 1$. (U.L.)

12. Prove that the relation $w = i \sinh z$ maps the semi-infinite rectangle $x > 0$, $-\pi/2 < y < \pi/2$ in the z -plane on the upper half of the w plane. Show that the ratio of the area of the finite part of this rectangle cut off by the line $x = a$ to the corresponding area in the w -plane is $4a/\sinh 2a$. (U.L.)

13. A region in the z -plane is bounded by two cuts along the real axis from 1 to $+\infty$ and from -1 to $-\infty$. Variables w and Z are connected with z by the equations $z = \cosh w$, $Z = \sinh w$. Find the regions in the w - and Z -planes which correspond to the above region in the z -plane. (U.L.)

14. Show that, by the transformation $w = a \cos(\pi z/a)$, the space above the axis of x and between the lines $x = \pm a$ is transformed into the whole w -plane. Determine the region in the w -plane which corresponds to the interior of the square in the z -plane bounded by the lines

$$x = \pm a/4, y = a, y = 3a/2. \quad (U.L.)$$

15. Prove that, by the transformation $w = \tanh z$, the region of the z -plane, for which

$$a > x > 0, \pi/2 > y > 0$$

(a real and positive), is transformed into that part of the positive quadrant in the w -plane which lies outside a certain circle having its centre on the real axis.

Show also that the part of the z -plane for which

$$x > a, \pi/2 > y > -\pi/2,$$

is transformed into the interior of the same circle, cut along the real axis from the circumference to the point $w = 1$. (U.L.)

16. Show that the relation $w = 2z/(1 + z^2)$ maps the region outside a straight cut between the points $w = \pm 1$ in the w -plane on the upper half of the z -plane.

17. Show that $z = 4aw \cot \alpha / (1 + 2w \cot \alpha - w^2)$, where

$$0 < \alpha < \pi/4,$$

gives a conformal representation of w when w lies in any finite region excluding the points $w = \pm i$, $\cot \frac{1}{2}\alpha$, $-\tan \frac{1}{2}\alpha$.

Prove that, when w describes the circle $|w| = 1$, z describes an arc of a circle subtending an angle 4α at the centre.

Show also that, when w describes the real axis from $-\tan \frac{1}{2}\alpha$ to $\cot \frac{1}{2}\alpha$, z describes the whole of the real axis. (U.L.)

18. If $w = z^2 - 3z$ and the point z describes an ellipse whose foci are at the points $z = \pm 2$, prove that the point w describes a confocal ellipse. (U.L.)

19. If $x + iy = \coth(u + iv)$, express x and y in terms of u and v . Show that the curves in the xy -plane given by $v = \text{const.}$ are circles through the points $(1, 0)$, $(-1, 0)$ and that the curves $u = \text{const.}$ are circles orthogonal to these.

Determine the region in the xy -plane corresponding to the interior of the rectangle bounded by $u = 0$, $u = 1$, $v = 0$, $v = \pi/4$ in the wv -plane.

20. Show that the relation $w = z + \log z$ maps the upper half of the z -plane on the upper half of the w -plane with a slit along the line $v = \pi$ ($u < 0$).

21. If $w = c \cos(k \log z)$, where $c^2 = a^2 - b^2$ and $\cosh(k\pi/2) = a/c$, prove that the area in the z -plane given by $x > 0$ and $1 < |z| < e^{\pi/k}$ is transformed conformally into the interior of the ellipse

$$(u/a)^2 + (v/b)^2 = 1$$

in the w -plane cut along the lines joining $(c, 0)$ to $(a, 0)$ and $(-c, 0)$ to $(-a, 0)$. (U.L.)

22. Discuss the transformation $z = \tanh \frac{1}{2}w$. In particular, prove that the curves given by $u = \text{const.}$ and $v = \text{const.}$ form two sets of coaxial circles in the z -plane; and that the interior of the unit circle which falls in the positive quadrant corresponds to the interior of the infinite rectangle in the w -plane of which the finite sides are given by $u = 0, v = 0, v = \pi/2$. (U.L.)

23. Show that the relation $w = ai \cot \frac{1}{2}z$ ($a > 0$) maps the semi-infinite strip in the z -plane for which $2\pi \geq x > 0, y \geq 0$, upon that half of the w -plane which lies to the right of the imaginary axis and which is cut along the real positive axis from $x = a$ to $x = +\infty$, and indicate the points at which conformal representation breaks down.

Two circles with real limiting points at $(\pm a, 0)$ are drawn in the cut w -plane whose centres are at the points $(pa, 0), (qa, 0)$, where $p > q > 1$. Show that the space between these circles is mapped on the interior of a rectangle in the z -plane whose area is

$$\log \left[\frac{(p-1)(q+1)(p+1)(q-1)}{4} \right] \quad (\text{U.L.})$$

24. Show that the region on the sphere which is represented in Mercator's Projection by a rectangle bounded by the lines

$$\phi = \phi_1, \phi = \phi_2, \psi = \psi_1, \psi = \psi_2,$$

is of area $a^2(\tanh \psi_1 - \tanh \psi_2)(\phi_1 - \phi_2)$.

Show also that a great circle on the sphere is represented in the map by a curve whose equation is of the form

$$\tanh \psi \sin(\phi + \alpha) = k,$$

where x and k are constants.

25. Show that, if (ϕ, θ) are the spherical co-ordinates of a point on a rhumb line, $A\phi + B \log \tan \frac{1}{2}\theta + C = 0$, where A, B, C are constants.

26. Prove that, in the stereographic projection, a rhumb line is represented by an equiangular spiral.

27. Show that a stereographic projection of a region on the sphere may be obtained by conical projection from S on to the tangent plane to the sphere at N (Fig. 35).

28. Show that the transformation

$$w = (az + 1)/(z + a),$$

where a is any real number except ± 1 , transforms the circle $|z| = 1$ into $|w| = 1$. If, further, the circle $|z - 1| = 1$ is transformed into $|w + 1| = 1$, find the value of a . (U.L.)

29. If $w = z - 2i + (1/z)$, and $|z| = 2$ show that the point w lies on an ellipse whose major and minor axes are 5, 3 respectively. (U.L.)

CHAPTER VI

THE SCHWARZ-CHRISTOFFEL TRANSFORMATION

Conformal Transformation of a Half-plane into a Polygon. Let P be the fixed point on the real axis in the z -plane at which $z = a$. Then if z has a real value greater than a (represented by S in Fig. 36) the principal value of $\arg(z - a)$ is zero. If the point z describes the semicircular arc SRQ with P as centre, $\arg(z - a)$ increases by π .

This is still true if the radius of the semicircle is made infinitesimal. Hence, if z is restricted to real values, it may be

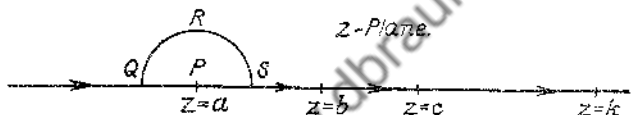

FIG. 36

said that $\arg(z - a)$, which is π when the point z is on the left of P , decreases to zero when z , moving from left to right along the real axis, passes through P .

Suppose that a, b, c, \dots, k are n real constants arranged in ascending order, and that

$$F(z) = (z - a)^{-\alpha} (z - b)^{-\beta} (z - c)^{-\gamma} \dots (z - k)^{-\kappa},$$

where $\alpha, \beta, \gamma, \dots, \kappa$ are n real constants each lying between -1 and 1 . Consider how the argument of $F(z)$ varies as z moves along the real axis from $-\infty$ to $+\infty$.

When z is on the left of a , the argument of each of the numbers

$$z - a, z - b, z - c, \dots, z - k$$

is π and, when z passes through a , the arguments are unaltered except that of the first, which decreases by π . Consequently, when z passes through a , the argument of $F(z)$ increases by $\alpha\pi$.

As z continues its motion between a and b , $\arg F(z)$ does not alter, but, when z passes through b , $\arg [(z - b)^{-\beta}]$ increases by $\beta\pi$ and the arguments of the other factors of $F(z)$ are unaltered.

Hence, when z moves from $-\infty$ to $+\infty$ along the real axis, $\arg F(z)$ increases by a total amount $(\alpha + \beta + \gamma + \dots + \kappa)\pi$.

Now suppose that w is a function of z determined by the differential equation

$$dw/dz = LF(z),$$

where L is a complex constant.

The functional relation between w and z , which would be obtained by integration, establishes a conformal transformation from the z - to the w -plane. Our present purpose is to find the region of the w -plane which is transformed into the upper half of the z -plane.

We shall assume that, when $z = a, b, c, \dots, k, \infty$, the corresponding values of w are A, B, C, \dots, K, U , respectively.

If $\delta w, \delta z$ are corresponding infinitesimal increments in the two variables, we have, from the differential equation,

$$\arg \delta w = \arg \delta z + \arg F(z) + \arg L.$$

As z moves from $-\infty$ up to a , along the real axis, both $\arg \delta z$ and $\arg F(z)$ remain constant and therefore w moves from U to A in such a way that $\arg \delta w$ is constant. The path of w is therefore the straight line UA .

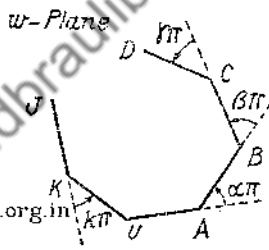

FIG. 37

When z passes through a , $\arg F(z)$ increases by $\alpha\pi$ and therefore $\arg \delta w$ increases by the same amount. As z continues its motion along the segment of the real axis between a and b , $\arg \delta w$ remains constant and therefore the point w moves along the straight line AB which makes with UA an angle $\alpha\pi$ measured in the positive sense.

Similarly, when z passes through b , $\arg \delta w$ increases by $\beta\pi$ and, as z moves from b to c , the point w moves along the straight line BC which makes with AB an angle $\beta\pi$ in the positive sense; and so on. After z has passed through k , w moves along the straight line KU which makes an angle $\kappa\pi$ with JK .

Hence, as z describes the real axis, w describes the complete perimeter of the $(n + 1)$ -sided polygon $ABC \dots KU$. Since the upper half of the z -plane is on the left of an observer moving with z , the interior of the polygon is the corresponding area in the w -plane. It is only at the vertices of the polygon that the transformation is not conformal; for these are the only points at which dw/dz becomes zero or infinite.

It will be noted that, in general, one vertex of the polygon in the w -plane is the point U which corresponds to the point at infinity in the z -plane. The exterior angle of the polygon at U is

$$2\pi - (\alpha + \beta + \gamma + \dots + \kappa)\pi.$$

If, then,

$$\alpha + \beta + \gamma + \dots + \kappa = 2,$$

the points K, U, A are collinear and the half of the z -plane is transformed into an n -gon $ABC \dots K$ all of whose vertices correspond to finite values of z .

In drawing Fig. 37 it has been assumed that $\alpha, \beta, \gamma, \dots, \kappa$ are all positive. The interior angles of the polygon are $(1 - \alpha)\pi, (1 - \beta)\pi, \dots$ and are all less than π so that the polygon is

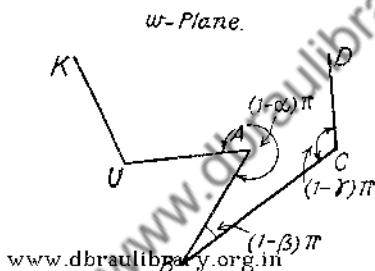

FIG. 38

convex. If α is negative, the interior angle lies between π and 2π and the polygon has a re-entrant angle as in Fig. 38.

Transformation of the Interior of a Polygon into a Half-plane.

Now suppose that a given polygon P , of n sides, in the w -plane, is to be transformed into the upper half of the z -plane. The figure may be convex or may have one or more re-entrant angles. In either case no interior angle exceeds 2π . Taking the vertices in the order which corresponds to the positive sense of describing the perimeter, we can measure the interior angles $(1 - \alpha)\pi, (1 - \beta)\pi, \dots, (1 - \kappa)\pi$. The constants $\alpha, \beta, \dots, \kappa$ are thus known (their sum being 2).

Suppose first that no vertex of P is to be transformed into the point at infinity in the z -plane.

Construct the function

$$F(z) = (z - a)^{-\alpha}(z - b)^{-\beta} \dots (z - k)^{-\kappa},$$

where the n constants a, b, \dots, k are real and in ascending order but their actual values are, as yet, unspecified.

Taking

$$dw/dz = LF(z),$$

which is equivalent to the relation

$$w = L \int F(z) dz + M,$$

where L and M are complex constants, we have a transformation which, as we have seen in the previous section, converts the upper half of the z -plane into an n -sided polygon P' in the w -plane. The interior angles of P' are $(1 - \alpha)\pi$, $(1 - \beta)\pi$, . . . $(1 - \kappa)\pi$, while the positions of the vertices depend on the values chosen for the constants.

The two polygons P , P' are thus equiangular but, if n exceeds 3, they are not necessarily similar. We have to show that the n real constants a, b, \dots, k and the complex constants L and M may be chosen in such a way that P' coincides with P .

The two equiangular polygons will be similar if the $n - 3$ ratios between $n - 2$ consecutive sides of P are equal to the corresponding ratios for P' . This gives $n - 3$ relations between the constants.

To make the figures coincide, it is now sufficient to make two vertices of P' coincide with the two corresponding vertices of P . This gives four more relations (two for each vertex).

Altogether, we have $n + 1$ relations to be satisfied by the n real constants and the real and imaginary parts of L and M , i.e. there are $n + 4$ constants connected by $n + 1$ relations. It follows that three of the constants may be chosen arbitrarily and that the remaining $n + 1$ are determinate.

If one vertex of the polygon is transformed into the point at infinity in the z -plane, the corresponding factor must be omitted from the expression for $F(z)$; so that the total number of (real) constants is now $n + 3$. The argument used above shows that these are connected by $n + 1$ relations and therefore two, and only two, may be chosen arbitrarily.

In practice, it is convenient to give arbitrary values to the appropriate number of the real constants which correspond to the vertices.

From any one transformation which converts the w -polygon into the half z -plane, an infinite number of such transformations may be derived. As was shown on p. 87, the real axis in the z -plane may be transformed into the real axis in the plane of another complex variable Z by the relation

$$(z z_1 z_2 z_3) = (Z Z_1 Z_2 Z_3),$$

where $z_1, z_2, z_3, Z_1, Z_2, Z_3$ are all real but otherwise arbitrary. If the points Z_1, Z_2, Z_3 occur in the same order as the points z_1, z_2, z_3 , then the upper halves of the two planes correspond. We now have two successive transformations, from w to z and from z to Z , by which the w -polygon becomes the upper half of the Z -plane.

The relation which converts the polygon into the half-plane is known as the *Schwarz-Christoffel Transformation*.

EXAMPLE 1. A triangle ABC in the w -plane with angles

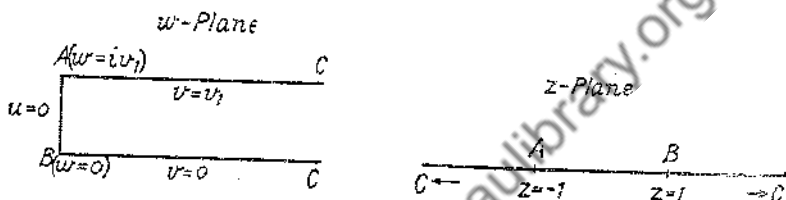

FIG. 39

$(1 - \alpha)\pi, (1 - \beta)\pi, (1 - \gamma)\pi$, is transformed into the upper half of the z -plane by the relation

$$dw/dz = L \frac{(z-a)^{\alpha-1}(z-b)^{\beta-1}}{(z-c)^{\gamma-1}}$$

where, since the sum of the angles is π , $\alpha + \beta + \gamma = 2$. The values of the real constants a, b, c may be chosen arbitrarily. In general, the differential equation is not integrable in terms of elementary functions.

There is a particular case which is of some importance in practice, and in which the integration is easy, viz. when $\alpha = \beta = \frac{1}{2}$ and $\gamma = 1$. The triangle then becomes a semi-infinite strip. By suitable choice of axes we can take it to lie in the positive quadrant and to be bounded by the lines $v = 0, u = 0, v = v_1$. The vertices A, B, C (Fig. 39) are then the points given by $w = iv_1, 0, \infty$, respectively, and we may take the corresponding points on the real axis of z to be given by $z = -1, +1, \infty$, respectively.

The required transformation will be given by

$$dw/dz = L(z+1)^{-\frac{1}{2}}(z-1)^{-\frac{1}{2}}$$

since the factor corresponding to the vertex C , at which z is to be infinite, must be omitted.

Integrating, we have

$$\begin{aligned} w &= L \int (z^2 - 1)^{-\frac{1}{2}} dz + M \\ &= L \cosh^{-1} z + M \\ &= L \log[z + (z^2 - 1)^{\frac{1}{2}}] + M, \end{aligned}$$

where the logarithm has its principal value.

At B , $w = 0$ and $z = 1$ and therefore M vanishes. At A , $w = iv_1$ and $z = -1$: hence L is determined by the condition that

$$iv_1 = L \log [z + (z^2 - 1)^{\frac{1}{2}}]$$

when $z = -1$. Now, if z is on or above the real axis, its principal

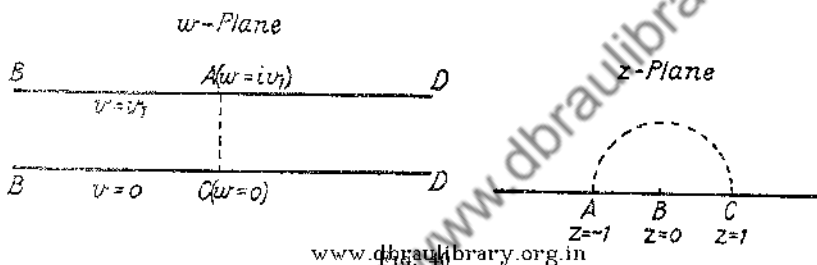

argument ranges from 0 to π . Consequently the appropriate value of the logarithm at $z = -1$ is $i\pi$ and it follows that

$$L = v_1/\pi.$$

The equation of the transformation may be written

$$w = (v_1/\pi) \cosh^{-1} z$$

or

$$z = \cosh (\pi w/v_1).$$

If now we apply a bilinear transformation which converts the upper half of the z -plane into the upper half of a Z -plane, we obtain a transformation from w to Z which has an effect similar to that from w to z . For instance, take $z = -1/Z$ and we have

$$Z = -\operatorname{sech} (\pi w/v_1)$$

as the relation which converts the strip into the upper half of the Z -plane in such a manner that the vertices B, C, A become the points $Z = -1, 0, 1$, respectively.

EXAMPLE 2. Consider the doubly infinite strip bounded by the lines $v = 0, v = v_1$ (Fig. 40).

The strip may be regarded as the limiting form of a rhombus $ABCD$ (where A and C are the points $w = iv_1$, $w = 0$, respectively) when each of the angles at A and C is made equal to π and those at B and D become zero. With the notation of p. 110, we have

$$1 - \alpha = 1 - \gamma = 1 \quad \text{and} \quad 1 - \beta = 1 - \delta = 0,$$

i.e. $\alpha = \gamma = 0$ and $\beta = \delta = 1$.

The real values of z at B , C , D may be chosen arbitrarily provided that they are in the proper order: for simplicity we take them to be 0 , 1 , ∞ , respectively. The transformation is then given by

$$dw/dz = Lz^{-1}$$

which gives

$$w = L \log z + M.$$

It will be noted that, since $\alpha = 0$, the value of z at A does not occur explicitly in the equation. On inserting the values at C ($w = 0$, $z = 1$) we see that M vanishes.

At any point on BD , z is positive and w is real and therefore the constant L is purely real. To determine its actual value, we consider the transformation from the z - to the w -plane of the semi-circle above the real axis which has unit radius and centre B . At any point on the arc, $z = \exp(i\theta)$, where $0 \leq \theta \leq \pi$, and so

$$w = u + iv = Li\theta,$$

from which we have

$$u = 0, \quad \text{and} \quad v = L\theta.$$

Therefore the semicircle corresponds to the straight line AC in the w -plane.

As z describes the arc in the clockwise sense, $\log z$ decreases by $i\pi$ and, as the corresponding point w moves from A to C , the value of w decreases by iv_1 .

It follows that

$$iv_1 = Li\pi$$

and so the equation of the transformation may be written

$$w = (v_1/\pi) \log z$$

or

$$z = \exp(\pi w/v_1).$$

EXAMPLE 3. Transform the doubly-infinite strip of the w -plane between the lines $v = 0, v = \pi$, when there is a slit along the line $v = v_1$ from the point $w = iv_1$ to the point at infinity (Fig. 41).

The given figure may be regarded as the limiting form of the quadrilateral $ABCD$ when the angle at A becomes 2π and all the other angles become zero. The vertex A is at the point $w = iv_1$ and all the other vertices are at infinity.

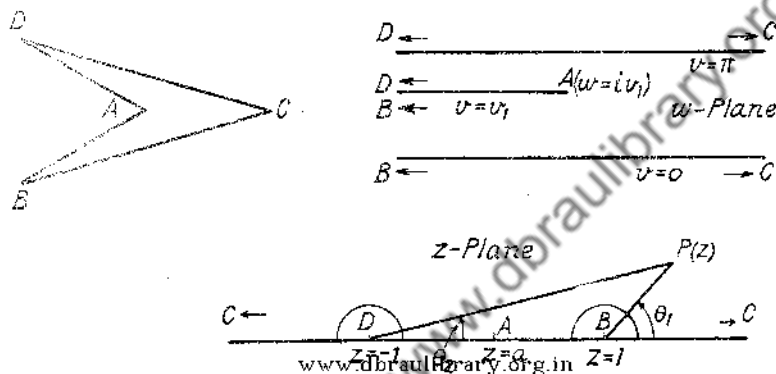

FIG. 41

The constants are now given by

$$1 - \alpha = 2, \quad 1 - \beta = 1 - \gamma = 1 - \delta = 0,$$

whence $\alpha = -1, \beta = \gamma = \delta = 1$.

We can take the values of z at D, A, B, C to be $-1, a, 1, \infty$, respectively, where a , which is yet to be determined, lies between -1 and 1 . The points are then in the correct order.

The transformation is given by

$$dw/dz = L(z + 1)^{-1}(z - a)(z - 1)^{-1},$$

since the factor corresponding to C has to be omitted.

Using partial fractions we may integrate this in the form

$$w = \frac{1}{2}L(1 - a) \log(z - 1) + \frac{1}{2}L(1 + a) \log(z + 1) + M,$$

the logarithms having their principal values.

Let a point z move from $-\infty$ to $+\infty$ along the real axis in the z -plane, making small semicircular detours above the axis about the points D and B in order to avoid the singularities

of $\log(z+1)$ and $\log(z-1)$. As the point moves round the semicircle which has D as centre, $\log(z+1)$ decreases by $i\pi$ while the variation in $\log(z-1)$ approaches zero when the radius is diminished to zero. At the same time, the corresponding point in the w -plane moves from a position near D on CD to a position near D on DA and so w decreases by an amount $i(\pi - v_1)$.

Equating the discontinuities in w and in the expression on the right-hand side of the equation of transformation, we have

$$i(\pi - v_1) = \frac{1}{2}L(1+a)i\pi.$$

Dealing similarly with the point B ($z=1$), we deduce that

$$iv_1 = \frac{1}{2}L(1-a)i\pi,$$

whence it follows that

$$L = 1 \text{ and } a = 1 - (2v_1/\pi).$$

The value of the constant M may be found by using the values at A , viz. $w = iv_1$, $z = a$.

If the slit is midway between the outer boundary lines, $v_1 = \pi/2$ and a vanishes. The constant M also vanishes and the equation takes the simple form

$$w = \frac{1}{2} \log(z^2 - 1), \text{ or } z^2 = 1 + e^{2w}.$$

EXAMPLE 4. Consider the doubly-infinite strip of which the width changes suddenly from h to k (Fig. 42). We may regard this figure as the limiting form of a quadrilateral $ABCD$ in which AD is along the line $v = k$, B is the point $w = i(k-h)$, and C the point $w = 0$. When the angles at B and C are made equal to $3\pi/2$ and $\pi/2$, respectively, the quadrilateral opens out into the strip, and we have, in the usual notation,

$$1 - \alpha = 1 - \delta = 0, \quad 1 - \beta = 3/2, \quad 1 - \gamma = 1/2$$

$$\text{and} \quad \alpha = \delta = 1, \quad \beta = -1/2, \quad \gamma = 1/2.$$

Taking the values of z at A, B, C, D to be $0, 1, c, \infty$, respectively, where c , which exceeds unity, is yet to be found, we have

$$\begin{aligned} dw/dz &= Lz^{-1}(z-1)^{\frac{1}{2}}(z-c)^{-\frac{1}{2}} \\ &= L(z-1)^{-\frac{1}{2}}(z-c)^{-\frac{1}{2}}(1-z^{-1}). \end{aligned}$$

Hence

$$w = L \int (z-1)^{-\frac{1}{2}}(z-c)^{-\frac{1}{2}} dz - L \int z^{-1}(z-1)^{-\frac{1}{2}}(z-c)^{-\frac{1}{2}} dz + M$$

$$= L \int (z-1)^{-\frac{1}{2}}(z-c)^{-\frac{1}{2}} dz + L \int (1-t)^{-\frac{1}{2}}(1-ct)^{-\frac{1}{2}} dt + M,$$

where $t = 1/z$.

Substituting $z = c \cosh^2 \theta - \sinh^2 \theta$,
we have

$$\int (z-1)^{-\frac{1}{2}}(z-c)^{-\frac{1}{2}} dz = 2\theta = \cosh^{-1} [(2z-c-1)/(c-1)].$$

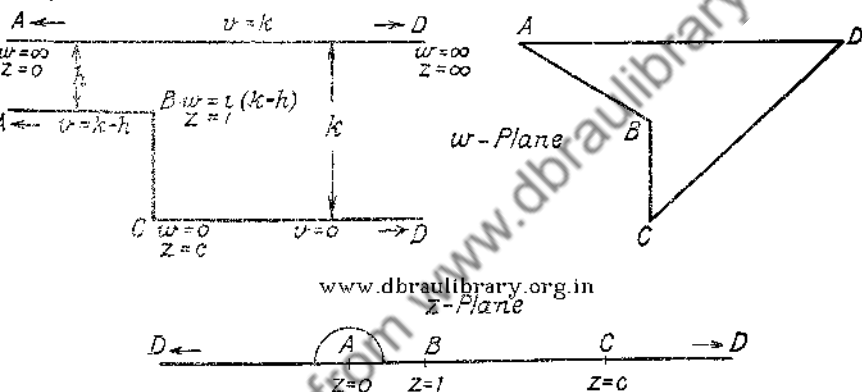

FIG. 42

Again, if

$$ct = \cosh^2 \phi - c \sinh^2 \phi,$$

$$\int (1-t)^{-\frac{1}{2}}(1-ct)^{-\frac{1}{2}} dt = -2c^{-\frac{1}{2}} \phi$$

$$= -c^{-\frac{1}{2}} \cosh^{-1} \{[(c+1)z-2c]/[(c-1)z]\}.$$

The relation between w and z is therefore

$$w = L \cosh^{-1} [(2z-c-1)/(c-1)]$$

$$- Lc^{-\frac{1}{2}} \cosh^{-1} \{[(c+1)z-2c]/[(c-1)z]\} + M,$$

where L , M , and c have to be determined.

Now the above expression for dw/dz in terms of z has a simple pole at $z = 0$ and the residue there is $Lc^{-\frac{1}{2}}$. When the point z moves counter-clockwise in a small semicircle about $A(z = 0)$ in the z -plane, w increases by ih , since the point w moves from

the line $v = k - h$ on to $v = k$. Hence, by equating the integral of dw/dz round the semicircle in the z -plane to the known increment of w , we have

$$\pi i L c^{-\frac{1}{2}} = ih.$$

(See Example 20, p. 76.)

Using the values at B ($w = i(k - h)$, $z = 1$) and C ($w = 0$, $z = c$) we find that

$$\begin{aligned} \pi i L (1 - c^{-\frac{1}{2}}) + M &= i(k - h) \\ M &= 0 \end{aligned}$$

and therefore

$$L = k/\pi \text{ and } c = (k/h)^2.$$

The equation of the required transformation is

$$\begin{aligned} w = (k/\pi) \cosh^{-1} [(2z - c - 1)/(c - 1)] \\ - (h/\pi) \cosh^{-1} \{(c + 1)z - 2c\} / [(c - 1)z]. \end{aligned}$$

EXERCISES

1. The z -plane is slit along the semi-infinite lines $x = \pm h$, $y \leq 0$. Prove that the region bounded by the edges of the slits can be transformed conformally into the half-plane $\text{Im } z > 0$ of a complex variable $Z (= X + iY)$ by means of an equation of the form

$$dz/dZ = Ai(Z^2 - 1)/Z.$$

where A is a real constant. Determine the value of A and express z in terms of Z . (U.L.)

2. Show that the region, in the positive quadrant of the w -plane, bounded by the lines $u = 0$, $v = 0$, $u = 1$ ($v > 1$), $v = 1$ ($u > 1$), is transformed into the upper half of the z -plane by the relation

$$\pi w = \cosh^{-1} z - \sin^{-1} (1/z) + \pi/2.$$

3. Show that the relation

$$w = 2a(z + 1)^{\frac{1}{2}} + \log [(z + 1)^{\frac{1}{2}} + 1] - \log [(z + 1)^{\frac{1}{2}} - 1] + i\pi$$

maps the upper half of the z -plane on the positive quadrant of the w -plane with a slit along the line $v = \pi$, $u \geq h$, where $w = h + i\pi$ when $z = 1/a$, both a and h being real and positive.

CHAPTER VII

APPLICATION TO POTENTIAL PROBLEMS

Green's Theorem. On p. 66 we obtained Stokes's theorem in its two-dimensional form

$$\int_C (p \, dx + q \, dy) = \iint (q_x - p_y) \, dx \, dy \quad (1)$$

where suffixes denote partial derivatives.

Let (x, y) , $(x + dx, y + dy)$ be the ends of the arc ds of the curve C , and let γ be the angle between the x -axis and the inward-drawn normal at a point in ds (Fig. 19, p. 65). Then

$$dx = \cos(\gamma - \frac{1}{2}\pi) \, ds = \sin \gamma \, ds$$

and
$$dy = \sin(\gamma - \frac{1}{2}\pi) \, ds = -\cos \gamma \, ds.$$

In (1) put $p = \phi \theta_y$ and $q = -\phi \theta_x$, where ϕ and θ are any functions of x and y which, along with their first derivatives, are finite throughout the area bounded by C . Then

$$\begin{aligned} p \, dx + q \, dy &= \phi(\theta_y \, dx - \theta_x \, dy) \\ &= \phi(\theta_x \cos \gamma + \theta_y \sin \gamma) \\ &= \phi(\partial\theta/\partial n) \, ds, \end{aligned}$$

where dn is the element of the inward-drawn normal.

Hence equation (1) may be written

$$\int_C \phi(\partial\theta/\partial n) \, ds = - \iint [\phi(\theta_{xx} + \theta_{yy}) + \phi_x \theta_x + \phi_y \theta_y] \, dx \, dy \quad (2)$$

On interchanging θ and ϕ and subtracting the result from (2), we have Green's theorem in its two-dimensional form

$$\begin{aligned} &\int_C [\phi(\partial\theta/\partial n) - \theta(\partial\phi/\partial n)] \, ds \\ &= \iint [\theta(\phi_{xx} + \phi_{yy}) - \phi(\theta_{xx} + \theta_{yy})] \, dx \, dy \quad (3) \end{aligned}$$

In particular, if we make $\theta = \phi$ and assume ϕ to be a real potential function (i.e. $\phi_{xx} + \phi_{yy} = 0$), equation (2) gives

$$\int_C \phi(\partial\phi/\partial n) \, ds = - \iint (\phi_x^2 + \phi_y^2) \, dx \, dy \quad (4)$$

It follows that, if $\phi = 0$ at all points on the curve C , the double integral on the right-hand side of (4) vanishes. But, since the sum of two real squares cannot be negative, ϕ_x and ϕ_y must both be zero at all points of the region bounded by C . The function ϕ is therefore constant and, being zero on C , must be zero at all points of the region.

Again, if $\partial\phi/\partial n$ vanishes at all points on C , it follows in the same way that $\phi_x = \phi_y = 0$ and that ϕ is constant throughout the region.

Now suppose that ϕ and ϕ' are two potential functions which are equal at all points on C . Since $\phi - \phi'$ is a potential function which is zero at all points on C , it vanishes at all points of the region. It follows that there cannot be more than one potential function which has prescribed values at all the points of a simple closed contour.

Further, suppose that two potential functions ϕ and ϕ' have equal normal derivatives at all points on C . Then $\phi - \phi'$ is a potential function such that its normal derivative $(\partial/\partial n)(\phi - \phi')$ vanishes at all points on C . It must therefore be constant throughout the region. Thus the functions ϕ and ϕ' only differ by a constant.

As will be seen in the remainder of this chapter, two-dimensional problems in mathematical physics generally reduce to finding a potential function whose values, or those of its normal derivative, are prescribed on the boundary.

Hydrodynamics. When fluid moves in two dimensions, i.e. in such a way that the motion is the same in all planes parallel to a fixed plane, it is sufficient to consider the motion of a sheet of fluid in one of the planes, which we can take to be that of the complex variable z . If the fluid is incompressible and free from viscosity, irrotational motion (motion without spin) is determined by a velocity potential ϕ whose value at any point (x, y) is a function of x, y , and, in general, the time. If ϕ is independent of the time, the motion is *steady*.

The component velocities in the directions of the axes at the point (x, y) are $-\phi_x, -\phi_y$. The equation of continuity, which expresses the fact that matter is being neither created nor destroyed, becomes

$$\phi_{xx} + \phi_{yy} = 0,$$

which is Laplace's equation in two dimensions.

From p. 51, it follows that, if ϕ satisfies this equation, there

is a function of the complex variable $z = x + iy$ which has ϕ for its real part; thus

$$w = \phi + i\psi = f(z).$$

The function ψ , which is the conjugate of ϕ , is called the *stream function* and w is called the *complex potential*.

Since $\phi_x = \psi_y$ and $\phi_y = -\psi_x$, the component velocities at (x, y) are $-\psi_y, \psi_x$ and the differential equation to the stream lines may be written

$$-dx/\psi_y = dy/\psi_x$$

or

$$\psi_x dx + \psi_y dy = 0.$$

On integrating we have the equation of the stream lines in the form $\psi = \text{constant}$. These lines are cut orthogonally by the equipotential lines $\phi = \text{constant}$.

Let the velocity of the fluid at the point (x, y) be q in a direction which makes an angle α with the positive direction of the x -axis. Then

$$\psi_y = \phi_x = -q \cos \alpha, \quad \psi_x = -\phi_y = q \sin \alpha$$

and therefore

$$\text{www.dbraulibrary.org.in}$$

$$\begin{aligned} dw/dz &= \phi_x + i\psi_x \\ &= -q(\cos \alpha - i \sin \alpha) \\ &= q \exp [i(\pi - \alpha)]. \end{aligned}$$

Hence $q = |dw/dz|$ and $\pi - \alpha = \arg(dw/dz)$.

By taking any function of z as complex potential, we obtain immediately a possible form of the stream lines in an irrotational motion in two dimensions.

EXAMPLE 1. If $w = \phi + i\psi = U(x + iy)$, where U is real and positive, the stream lines are the parallel straight lines $y = \text{constant}$. Since $\phi_x = U$ and $\phi_y = 0$, the velocity is everywhere equal to U in the negative direction of the x -axis.

EXAMPLE 2. If $w = U(x + iy)^2$ the stream lines are the rectangular hyperbolas $xy = \text{constant}$.

EXAMPLE 3. Let

$$\begin{aligned} w &= U(z + a^2/z) \\ &= U(r + a^2/r) \cos \theta + iU(r - a^2/r) \sin \theta, \end{aligned}$$

where $z = r \exp(i\theta)$ and U is real and positive.

The stream lines are given by

$$\psi = U(r - a^2/r) \sin \theta = \text{constant}$$

and the line $\psi = 0$ reduces to the circle $r = a$ and the straight lines $\theta = 0, \theta = \pi$.

Since a stream line may be made a rigid boundary, we obtain the complex potential for the flow past a cylinder whose trace on the xy -plane is the circle $r = a$.

With the notation used above,

$$-q \exp(-i\alpha) = U(1 - a^2/z^2)$$

from which it is seen that, at infinity

$$-q \exp(-i\alpha) = U.$$

Thus at an infinite distance from the cylinder, $q = U$ and $\alpha = \pi$, i.e. there is parallel streaming with velocity U in the negative direction of the real axis.

It should be noticed that the complex potential consists of two terms: Uz which corresponds to the parallel streaming and Ua^2/z which represents the disturbance produced by the cylinder.

Writing $ze^{-i\beta}$ in place of z , which is equivalent to turning the axes through an angle β , we get

$$w = U(ze^{-i\beta} + a^2e^{i\beta}/z) \quad (5)$$

as the complex potential for flow past the cylinder when the undisturbed velocity of the stream is U inclined at an angle β to the negative direction of the x -axis.

CONFORMAL TRANSFORMATION. Let $\phi + i\psi = f(z)$ be the complex potential for the motion of a sheet of fluid in the z -plane. The boundaries, supposed rigid, will then be curves of the family $\psi = \text{constant}$. If we apply a conformal transformation

$$z = F(Z)$$

from the z - to the Z -plane, where $Z = X + iY$, we have

$$\phi + i\psi = f(z) = f[F(Z)] = G(Z), \text{ say.}$$

Thus ϕ and ψ , considered as functions of X and Y , are the velocity potential and the stream function for a motion in the Z -plane, the boundaries being the curves into which the original boundaries are transformed.

By applying this principle, it is possible to deduce from a known motion an unlimited number of others.

EXAMPLE 4. It was shown on p. 93 that the transformation

$$Z = z + a^2/z$$

converts the circle $|z| = a$ into a straight line (a degenerate ellipse) between the points $Z = \pm 2a$.

If we apply this transformation to the result (5) on p. 122, we obtain the complex potential for flow past a flat plate of width $4a$ inclined at an angle β to the general direction of the stream which, at infinity, has a speed U .

Electrostatics. Suppose that electric charges are so distributed that conditions are the same in all planes parallel to that of the complex variable z . The electric field is then two-dimensional and it is sufficient to consider points in the z -plane.

The potential V at the point z is a real function of x and y which, if the point is free from charge, satisfies the equation

$$V_{xx} + V_{yy} = 0.$$

It follows that we can find a function of z which has V for its imaginary part; thus

$$W = U + iV = f(z).$$

The equipotential lines $V = \text{constant}$ are cut orthogonally by the lines of force $U = \text{constant}$. The equipotential surfaces are, of course, cylinders of which the curves $V = \text{constant}$ are the cross-sections. Included among these are the surfaces of conductors.

The components of electric force at the point z are $-V_x$, $-V_y$ and so the resultant intensity R is given by

$$R^2 = V_x^2 + V_y^2 = U_x^2 + V_x^2 = |dW/dz|^2.$$

By the conformal transformation $z = F(Z)$, W becomes the complex potential for a field in the Z -plane in which the equipotentials are obtained by transforming the equipotentials in the z -plane. The values of V are the same at corresponding points in the two planes.

EXAMPLE 5. Consider Example 3 on p. 115, which is illustrated by Fig. 41.

If P (with affix z) is any point in the upper half of the z -plane and $\theta_1 = \angle CBP$, $\theta_2 = \angle CDP$, then the function

$$V = (k/\pi) (\theta_1 - \theta_2),$$

where k is real, is the imaginary part of

$$(k/\pi)[\log(z-1) - \log(z+1)]$$

and is therefore a potential function.

When P is on BC or CD , V vanishes and, when P is on DAB , $V = k$. Hence the function V is the potential when BC and CD are conductors at zero potential and DAB is a conductor at potential k . The equipotential lines are circular arcs joining B and D .

On transforming the figure in the z -plane by the relation

$$w = \frac{1}{2}L(1-a) \log(z-1) + \frac{1}{2}L(1+a) \log(z+1) + M$$

given on p. 115, we obtain the form of the potential in the field due to two parallel plates, at zero potential, when a plate at potential k is placed between them.

When the third plate is midway between the other two we have

$$U + iV = (k/\pi) \log [(z-1)/(z+1)],$$

where $z^2 = 1 + e^{2w}$.

Current Flow in a Plane Sheet. Suppose that an electric current flows in a uniform plane sheet of metal which coincides with the z -plane. The potential V satisfies Laplace's equation in two dimensions and so, as before, we must have a relation of the type

$$U + iV = f(z),$$

where U may be called the current function. The lines of flow are given by $U = \text{constant}$, and among these are included the boundaries of the sheet.

It is easily seen that the conditions are similar to those of two-dimensional flow of a fluid for which the complex potential is $if(z)$. Suppose, for instance, that the sheet is infinite in extent, and that the lines of flow are parallel straight lines. If now a circular hole is made in the sheet, the conditions are exactly like those of the flow of fluid past a circular cylinder, a case which has been considered above (p. 122).

Just as in hydrodynamics, conformal transformations may be used to obtain further results from known solutions.

Conduction of Heat. Let heat flow steadily in two dimensions parallel to the z -plane in material of uniform conductivity K . If θ is the temperature at the point z , the flux of heat at that point in the x -direction is $-K\theta_y$ and the flux in the y -direction is $-K\theta_x$. From the fact that there is no net gain or loss of heat in a rectangle of sides dx, dy with one corner at the point (x, y) , it is deduced that

$$\theta_{xx} + \theta_{yy} = 0.$$

Consequently in the theory of heat-flow there occurs the relation

$$\phi + i\theta = f(z).$$

The lines of flow $\phi = \text{constant}$ are cut orthogonally by the isothermals $\theta = \text{constant}$.

EXAMPLE 6. In Example 1 on p. 112, we transformed the semi-infinite strip of the w -plane, bounded by $v = 0, u = 0, v = v_1$, into the upper half of the z -plane by means of the relation

$$z = \frac{w}{\cosh(\pi w/v_1)}.$$

Suppose that the strip is of uniform thermal conductivity and that the parallel edges BC and AC (Fig. 39) are kept at zero temperature, while AB is kept at a uniform temperature T .

In the corresponding figure in the z -plane, we have $\theta = T$ on AB and $\theta = 0$ on AC and BC .

$$\text{Hence } \phi + i\theta = (T/\pi) \log \left\{ \frac{(z-1)}{(z+1)} \right\}$$

and so, in the w -plane,

$$\begin{aligned} \phi + i\theta &= (T/\pi) \log \left\{ \frac{[\cosh(\pi w/v_1) - 1]}{[\cosh(\pi w/v_1) + 1]} \right\} \\ &= (2T/\pi) \log \tanh(\pi w/2v_1). \end{aligned}$$

EXERCISES

1. If $\phi + i\psi = f(z)$, show that $\partial\phi/\partial s = \partial\psi/\partial n$ and $\partial\phi/\partial n = -\partial\psi/\partial s$, where ds and dn are the elements of the arc and inward normal of the curve C in Fig. 19, p. 65.

2. Sketch the equipotentials and stream lines when the complex potential has the values $z^{-2}, e^z, \cos z, z^{\frac{1}{2}}, \tan^{-1} z$.

3. Two infinitely long uniform circular cylinders, placed with their axes parallel, attract according to the Newtonian law. The gravitational

potential V at a point outside both cylinders and at distances r, r' from their axes is given by

$$V = \text{constant} - 2k \log (rr').$$

where k is a constant. Prove that the lines of force outside the cylinders are arcs of rectangular hyperbolas.

4. Find the isothermals and lines of flow in the strip discussed in Example 6 on p. 125 and show that the resultant flux of heat at the point (u, v) is $(4KT/v_1)/\cosh(2\pi u/v_1) - \cos(2\pi v/v_1)$.

5. Assuming that the pressure p and the velocity q satisfy Bernoulli's equation $(p/\rho) + \frac{1}{2}q^2 = \text{constant}$, show that, in liquid, of uniform density ρ which flows steadily, parallel to the z -plane, with complex potential w , the curves of constant pressure are the level curves of the function dw/dz .

6. Prove that, if $u + iv = f(x + iy)$,

$$V_{xx} + V_{yy} = |f'(x + iy)|^2 (V_{uu} + V_{vv}).$$

CHAPTER VIII

APPLICATION TO THE THEORY OF ALTERNATING CURRENTS

Notation. Throughout this chapter, which is devoted to a brief discussion of the application of the complex variable to the theory of alternating currents, we shall conform to the customary notation of the electrical engineer by using the symbol i to denote the current and j for $\sqrt{-1}$.

Harmonic Vectors. Let a point P in the Argand diagram move with uniform angular speed ω radians per second in a circle of radius a which has the origin as centre (Fig. 43). If at zero time the point is at P_0 on the real axis, at time t the angle P_0OP (known as the *phase angle*) is ωt and the rotating vector represents, at the time t , the complex number λ given by

$$\lambda = a \exp(j\omega t).$$

www.dbraulibrary.org.in

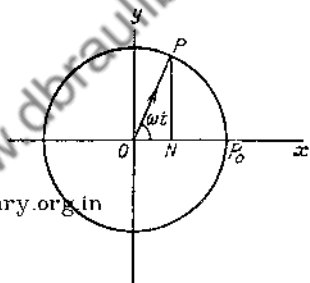

FIG. 43

If N is the foot of the ordinate at P , the motion of N is defined to be *simple harmonic motion*. Since all the characteristics of the motion of N are determinate when the vector \overline{OP} is given, we call \overline{OP} a *harmonic vector*.

\overline{OP} completes a revolution, and therefore N completes an oscillation, in time $2\pi/\omega$, which is defined as the *period*. The number of revolutions of \overline{OP} (or oscillations of N) per second is defined as the *frequency* and is $\omega/2\pi$.

Vector Representation of an Alternating Current. An alternating current is a periodic function of the time. The simplest type of such a current is that given by

$$i = i_0 \cos \omega t \quad . \quad . \quad . \quad (1)$$

where i_0 is the maximum value of the current. A complete cycle occurs in the period $2\pi/\omega$, and the frequency is $\omega/2\pi$ cycles per second.

In practice, alternating currents may not always be given

by expressions so simple as this, but since, by Fourier's theorem, a function $f(t)$ which has a period $2\pi/\omega$ is expressible in the form

$$f(t) = \frac{1}{2}a_0 + \sum_{n=1}^{\infty} (a_n \cos n\omega t + b_n \sin n\omega t),$$

where the a 's and b 's are constants, it is sufficient for our purpose to consider a single term like $i_0 \cos \omega t$. Results obtained for this term will be similar to those obtained for any other term in the series; and for the majority of circuits all these results may be superposed to give the result for $f(t)$. A sine term, of course, is not essentially different from a cosine: for we may write $\sin \omega t$ as $\cos(\omega t + 3\pi/2)$.

It will be noticed that equation (1) is of exactly the same form as that which gives the displacement of the point N considered on p. 127, viz.

$$ON = a \cos \omega t.$$

Just as the characteristics of the motion of N may be deduced from the harmonic vector OP which represents λ , so we may discuss the alternating current i by making use of a *current vector* which represents a complex number I defined by the relation

$$I = i_0 \exp(j\omega t).$$

The actual value of the current at the instant is then given by the real part of I .

On differentiating with respect to t we have

$$dI/dt = j\omega i_0 \exp(j\omega t),$$

from which it is seen that differentiating with respect to t is equivalent to multiplication by $j\omega$.

Impedance of an Inductive Coil. Suppose that the alternating current i is produced in a coil of inductance L and resistance R , where L and R are both constant and are expressed in suitable physical units. Then, if v is the potential difference between the ends of the coil at time t , the well-known equation for the current in an inductive circuit gives

$$\begin{aligned} v &= Ri + L(di/dt) \\ &= \text{the real part of } (R + j\omega L)I, \end{aligned}$$

where v is expressed in volts when i is in amperes, R in ohms, and L in henrys.

Hence the potential difference v is the real part of a complex number V , such that

$$V = (R + j\omega L)I = zI \quad (2)$$

where $z (= R + j\omega L)$ is a complex constant which is defined to be the *impedance* of the coil. The imaginary part of the impedance is ωL and is defined to be the *reactance*: the real part of the impedance is seen to be the *resistance* R .

Writing z in the form $Z \exp(j\phi)$, we have

$$V = Zi_0 \exp(j\omega t + j\phi) \quad (3)$$

The voltage vector, which represents V , is therefore of length Zi_0 and its phase is in advance of that of I by an acute angle ϕ such that $\tan \phi = \omega L/R$. It follows that the voltage vector is itself harmonic.

It will be noticed that the voltage and current vectors are in the same phase only when L vanishes, i.e. when the coil is non-inductive.

The reciprocal of the impedance is called the *admittance*: in this instance its value is

$$1/(R + j\omega L) = (R - j\omega L)/(R^2 + \omega^2 L^2).$$

Impedance of a Condenser. Let a condenser of capacitance C farads be included in a circuit in which alternating current i is flowing. If q is the quantity of electricity (expressed in coulombs) stored in the condenser and v is the potential difference (in volts) across the plates at time t ,

$$v = q/C \text{ and } dq/dt = i.$$

Hence

$$dv/dt = i/C$$

and so

$$j\omega V = I/C,$$

where V and I are the potential and current vectors.

We have therefore

$$V = (-j/\omega C)I = zI,$$

where, as before, z is the impedance, which for the condenser is $(-j/\omega C)$, a purely imaginary quantity.

Now since

$$\arg(-j/\omega C) = -\pi/2$$

$$\arg V = \arg I - \pi/2,$$

so that the potential difference vector lags behind the current vector by a quarter of a period.

Impedances in Series. Let a number of elements of impedance z_1, z_2, \dots, z_n be connected in series (Fig. 44). Then, with the same notation as before, the potential difference is given by

$$v = \text{the real part of } (z_1 I + z_2 I + \dots + z_n I),$$

i.e. $V = (z_1 + z_2 + \dots + z_n)I.$

The impedance of the system in series is thus the sum of the separate impedances.

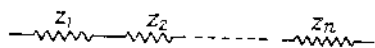

FIG. 44

Impedances in Parallel. Let

i_1, i_2, \dots, i_n be the currents in the n parallel sections of impedance z_1, z_2, \dots, z_n (Fig. 45), corresponding current vectors.

and let I_1, I_2, \dots, I_n be the corresponding current vectors. Then if the potential difference vector is V ,

$$V = z_1 I_1 = z_2 I_2 = \dots = z_n I_n$$

and $I = I_1 + I_2 + \dots + I_n$

$$= \left[\frac{1}{z_1} + \frac{1}{z_2} + \dots + \frac{1}{z_n} \right] V = [\Sigma(1/z)]V.$$

The admittance of the system of parallel impedances is therefore the sum of the admittances of the elements of the

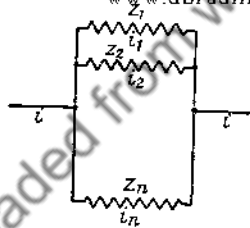

FIG. 45

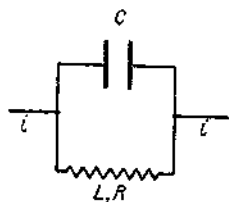

FIG. 46

system. The impedance is the reciprocal of the admittance and is equal to

$$1/(\Sigma(1/z)).$$

EXAMPLE 1. To find the impedance of a condenser and a coil in parallel (Fig. 46).

The impedance of the condenser is $(1/j\omega C)$ and that of the coil is $R + j\omega L$. The admittance of the two in parallel is therefore

$$j\omega C + 1/(R + j\omega L) = (1 - \omega^2 CL + j\omega CR)/(R + j\omega L).$$

On inverting this we have the impedance

$$(R + j\omega L)/(1 - \omega^2 CL + j\omega CR)$$

$$\rightarrow [R + j\omega(L - \omega^2 CL^2 - CR^2)]/[(1 - \omega^2 CL)^2 + \omega^2 C^2 R^2].$$

The denominator of the expression has been made real by the usual device of multiplying by the conjugate number.

Impedance of Parallel Wires. Let the ends B and D of two equal parallel wires be connected and let an alternating potential difference be maintained between the ends A and C (Fig. 47).

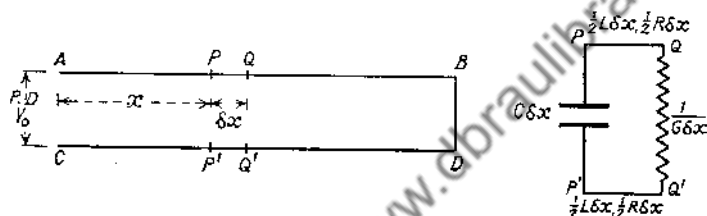

FIG. 47
www.dbraulibrary.org.in

The circuit or "loop" has four primary constants:

- (i) The resistance R ohms per unit length of the pair of wires.
- (ii) Since insulators are never perfect, there is a certain amount of leakage from wire to wire. If the conductance of the path of leakage between unit lengths of the two wires be G mhos, we may define the *leakance* to be G per unit length of loop.
- (iii) The inductance L henries per unit length of loop.
- (iv) The capacitance between wire and wire which we take to be C farads per unit length of loop.

We shall suppose that, at time t , the current is flowing in the sense AB, DC . If P and P' are points on AB and CD such that $AP = CP' = x$, the strength of the current i at P is clearly equal to that at P' , in other words, the current i at the instant is a function of x only. As usual, we take I to be the corresponding current vector. Take $PQ = P'Q' = \delta x$; then each of the elements $PQ, P'Q'$ is of resistance $\frac{1}{2}R\delta x$, inductance $\frac{1}{2}L\delta x$, and impedance $\frac{1}{2}(R + j\omega L)\delta x$.

Suppose that the potential difference between P and P' is v , then that between Q and Q' is $v + \delta v$; the corresponding vectors are V and $V + \delta V$.

Now if E_p denotes the potential at P ,

$$E_p - E_{p'} = v$$

and

$$E_q - E_{q'} = v + \delta v,$$

whence

$$E_p - E_q + E_q - E_{p'} = -\delta v. \quad (4)$$

But each of the potential differences $(E_p - E_q)$, $(E_q - E_{p'})$ is the real part of $\frac{1}{2}(R + j\omega L)\delta x.I$, and so we have, from (4),

$$-\delta v = \text{the real part of } (R + j\omega L)\delta x.I.$$

Therefore

$$-\delta V = (R + j\omega L)\delta x.I,$$

which gives, after dividing by $-\delta x$ and making δx tend to zero,

$$dV/dx = -(R + j\omega L)I. \quad (5)$$

Now the flow between PQ and $P'Q'$ is that due to a condenser of capacity $C\delta x$ and a conductance $G\delta x$ in parallel. The resultant conductance is

$$G\delta x + j\omega C\delta x$$

and the current shunted between the wires is therefore the real part of

$$(G\delta x + j\omega C\delta x)V.$$

www.dbraulibrary.org.in

Since the loss of current in the section is the real part of $-\delta I$, it follows that

$$\delta I = -(G + j\omega C)\delta x.V$$

and that

$$dI/dx = -(G + j\omega C)V. \quad (6)$$

Differentiating (5) with respect to x and using (6), we get

$$\begin{aligned} d^2V/dx^2 &= -(R + j\omega L) (dI/dx) \\ &= (R + j\omega L) (G + j\omega C)V \end{aligned} \quad (7)$$

In a similar way it may be shown that

$$d^2I/dx^2 = (R + j\omega L) (G + j\omega C)I \quad (8)$$

so that V and I satisfy the same differential equation

$$d^2y/dx^2 = k^2y,$$

where

$$k^2 = (R + j\omega L) (G + j\omega C). \quad (9)$$

The most general value of V which satisfies (7) is given by

$$\begin{aligned} V &= a \exp(kx) + b \exp(-kx) \\ &= (a + b) \cosh kx + (a - b) \sinh kx, \end{aligned}$$

where a and b may be determined from the end conditions. In

this case a and b , although independent of x , are functions of t . If the potential difference between A and C at the instant is $v_0 \cos \omega t$, then the conditions which determine a and b are that

$$V = V_0 = v_0 \exp(j\omega t) \text{ when } x = 0$$

and $V = 0$ when $x = AB = l$, say.

Thus $a + b = V_0$ and $(a + b) \cosh kl + (a - b) \sinh kl = 0$, from which

$$\begin{aligned} V &= V_0 \cosh kx - V_0 \coth kl \sinh kx \\ &= V_0 \operatorname{cosech} kl \sinh (kl - kx). \end{aligned} \quad (10)$$

The value of I may now be obtained from (5), and is

$$\begin{aligned} I &= -[1/(R + j\omega L)](dV/dx) \\ &= [(G + j\omega C)/(R + j\omega L)]^{\frac{1}{2}} \operatorname{cosech} kl \cosh (kl - kx). \end{aligned}$$

EXERCISES

1. An inductive coil is of resistance R ohms and inductance L henries; a non-inductive coil is of resistance r ohms; and a condenser is of capacitance C farads. Show that the impedance of

(i) the first coil and the condenser in series is

$$R + [j(\omega^2 CL - 1)/\omega C];$$

(ii) the second coil and the condenser in parallel is

$$R(1 - j\omega CR)/(1 + \omega^2 C^2 R^2);$$

(iii) the two coils in parallel is

$$[r(R^2 + Rr + \omega^2 L^2) + j\omega Lr]/[(R + r)^2 + \omega^2 L^2].$$

Also, find the admittance of each of the above in the form $A + jB$.

2. Show that, if I_0 and V_0 are the current and potential difference vectors at the ends A, C of the parallel wires (p. 131) and $Z_0^2 = (R + j\omega L)/(G + j\omega C)$,

$$V = V_0 \cosh kx - I_0 Z_0 \sinh kx$$

and $I = I_0 \cosh kx - (V_0/Z_0) \sinh kx$.

If the length of the loop is made infinite, show that

$$V = V_0 \exp(-kx) \text{ and } I = (V_0/Z_0) \exp(-kx).$$

3. If the ends B, D of the parallel wires are not connected, show that

$$V = V_0 \operatorname{sech} kl \cosh (kl - kx)$$

and $I = (V_0/Z_0) \operatorname{sech} kl \sinh (kl - kx)$.

APPENDIX

SUGGESTIONS FOR FURTHER READING

THE literature of the subject is so vast that some suggestions as to further reading (in English) may be helpful.

The subjects introduced in the first three chapters of this book are treated in Hardy's *Course of Pure Mathematics*, the whole of which is indispensable to the intending mathematical specialist; in Hobson's *Plane Trigonometry*; and in Bromwich's *Theory of Infinite Series*.

In connection with Chapters IV-VI, the reader may consult Titchmarsh's *Theory of Functions*, Harkness and Morley's *Introduction to the Theory of Analytic Functions*, Whitaker and Watson's *Modern Analysis* (especially Chapters V and VI), and Carathéodory's *Conformal Representation*. Forsyth's *Theory of Functions of a Complex Variable* is an exhaustive treatise on the whole subject.

Full details of the applications to mathematical physics will be found in the special treatises such as Jeans' *Electricity and Magnetism*, Livens' *Theory of Electricity*, Lamb's *Hydrodynamics*, Milne-Thomson's *Theoretical Hydrodynamics* and Carslaw's *Mathematical Theory of the Conduction of Heat*. An illuminating account of applications to these, as well as other subjects, is to be found in Bateman's *Partial Differential Equations of Mathematical Physics*. dbbraulibrary.org.in

The engineering student will find plenty to interest him in the *Theory of Functions as applied to Engineering Problems* by Rothe, Ollendorff, and Pohlhausen (English translation published by the Technology Press, Massachusetts Institute of Technology). Interesting applications to aeronautics are given in Glauert's *Aerofoil and Airscrew Theory*. Miles Walker's *Conjugate Functions for Engineers* deals with applications of the Schwarz-Christoffel transformation to potential problems such as are of importance to the electrical engineer. The symbolic theory of alternating currents is given in Clayton's *Alternating Currents* and in *Telephone and Power Transmission* by Bradfield and John. The latter book contains many fully-worked numerical examples.

INDEX

- ADMITTANCE**, 129
 Aerofoil, 91, 94
 Affix, 6
 Alternating current, 127
 Amplitude, 6
 Analytic function, 63
 Argand diagram, 5
 Argument, 6
- BILINEAR** transformation, 84
- CAUCHY'S** theorem, 66
 Circular functions, 32
 —, generalized, 37
 Coaxial circles, 14
 Complex number, 4
 — potential 121
 — variable, 47
 Condenser, 129
 Conduction of heat, 125
 Conformal transformation, 79, 122
 Conjugate functions, 50
 — numbers, 5
 — roots, 21
 Contour, 65
 — integration, 74
 Convergence, 30
 Cross-ratio, 86
 Current-flow, 124
 Curvilinear integral, 64
- DOUBLE** points, 87
- ELECTROSTATICS**, 123
 Equations, roots of, 20
 —, theory of, 20
 Equipotentials, 121
 Exponential series, 31
- FACTORS**, 22, 33, 34
 Function of a complex variable, 48
 —, holomorphic, 63
 —, monogenic, 50
 —, rational, 67
- GREEN'S** theorem, 119
- HYDRODYNAMICS**, 91, 120
 Hyperbolic functions, 37
- IMAGINARY** number, unit, 2
 Impedance, 129
 — of parallel wires, 131
 Impedances in parallel, 130
 —, in series, 130
 Infinite series, 30
 Inversion, 82
 Isothermals, 125
- LAPLACE'S** equation, 51
 — in polars, 56
 Laurent series, 72
 Laurent's theorem, 74
 Level curves 58
 Logarithms, 35
 Loxodrome, 104
- MAPPING** of a sphere, 101
 Mapping of a sphere, 101
 Mercator's projection, 104
 Modulus, 6
 de Moivre's theorem, 22
- ORDINARY** point, 79
- PARABOLIC** transformation, 87
 Path of integration, 65
 Point at infinity, 84
 Pole, 63
 Polynomial, zero of, 20
 Potential function, 119
 —, complex, 121
 Principal argument, 6
- RECIPROCAL** transformation, 84
 Regular function, 63
 Residue, 69, 74
 Rhumb line, 104
 Roots of unity, 24
 — of any number, 25
- SCHWARZ-CHRISTOFFEL** transformation, 112
 Self-corresponding points, 87
 Singularity, 63
 —, accidental, 63
 —, essential, 74

Stereographic projection, 104	TAYLOR series, 71
Stokes' theorem, 85	Taylor's theorem, 74
Stream function, line, 121	
Successive transformation, 99	
Summation of series, 34	VECTOR, 2
Surface of moduli, 61	— harmonic, 127